

AZZURRA

LIME Ø

LIME Ø



**IL BAGNO LIME Ø,
UN MONDO
ACCOGLIENTE
CHE RACCONTA UNA
STORIA DI ELEGANZA
E DI DETTAGLI
DI CARATTERE**



The Lime Ø bathroom, a welcoming space that transmits a sense of elegance, details and character

La salle de bains Lime Ø, un monde accueillant qui raconte une histoire d'élégance et d'importants détails

Das Badezimmer Lime Ø, eine einladende Welt, die eine Geschichte von Eleganz und charakteristischen Details erzählt

El baño Lime Ø, un mundo acogedor que cuenta una historia de elegancia y de detalles de carácter

Questo catalogo presenta alcune interpretazioni di arredamento dell'ambiente bagno realizzate con elementi della collezione Lime Ø. Nella gamma Azzurra, questa proposta si caratterizza per la presenza, estetica e funzionale, di una maniglia: un segno di design importante e in grado da solo di rendere unica la personalità di un ambiente / This catalogue presents a series of bathroom furnishing ideas created with elements from the Lime Ø collection. In the Azzurra range, this proposal is characterised by the signature feature of a handle, that is both attractive and functional: a key design element which, by itself, injects a unique touch of character into a room / Ce catalogue présente des interprétations d'ameublement de salle de bains réalisées avec des éléments de la collection Lime Ø. Dans la gamme Azzurra, cette proposition se distingue par la présence, esthétique et le caractère fonctionnel d'une poignée : un élément de design important est capable, à lui tout seul, de rendre unique la personnalité d'une pièce / Dieser Katalog zeigt einige Einrichtungsinterpretationen des Badezimmers mit Elementen der Kollektion Lime Ø. In der Modellreihe Azzurra zeichnet sich diese Kollektion durch die Präsenz, die Ästhetik und Funktionalität eines Griffes aus: ein wichtiges Designmerkmal, das in der Lage ist die Persönlichkeit eines Raums einzigartig zu gestalten / Este catálogo presenta algunas interpretaciones de decoración del ambiente del baño realizadas con elementos de la colección Lime Ø. En la gama Azzurra, esta propuesta se caracteriza por la presencia, estética y funcionalidad de un tirador: una línea de diseño importante y que puede por sí solo personalizar un ambiente

LIME Ø

INDEX

Nelle pagine che seguono potrete addentrarvi in un'ampia rappresentazione della versatilità del sistema Lime Ø e incontrare l'idea di arredobagno che fa per voi, viaggiando tra composizioni, forme, linee, toni, volumi, finiture, materiali e ambienti. Buona visione.



Lime Ø/005 pag. 44



Lime Ø/006 pag. 52



Lime Ø/007 pag. 60



Lime Ø/008 pag. 68



Lime Ø/009 pag. 78

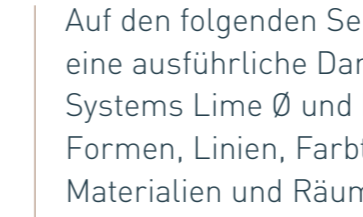

Lime Ø/010 pag. 88

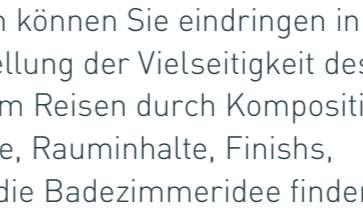

Lime Ø/011 pag. 98

The images on the following pages will give you an insight into the versatility of the Lime Ø system and let you discover the bathroom furnishing look that is right for you, by working your way through all the compositions, shapes, lines, shades, volumes, finishes, materials and layouts. Happy browsing.



Lime Ø/012 pag. 108



Lime Ø/013 pag. 118

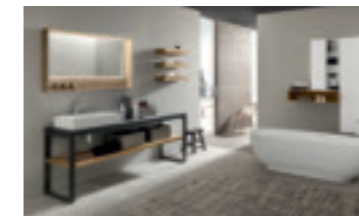

Lime Ø/014 pag. 128



Lime Ø/015 pag. 140



Lime Ø/016 pag. 152



Lime Ø/017 pag. 160



Lime Ø/018 pag. 172



Lime Ø/019 pag. 180

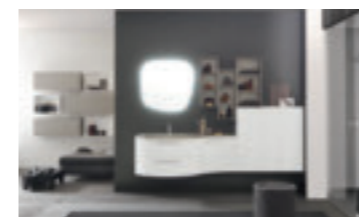

Lime Ø/020 pag. 190

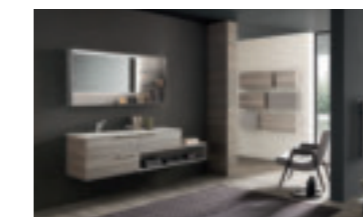

Lime Ø/021 pag. 200

Dans les prochaines pages vous vous immiscerez dans une vaste représentation de la polyvalence du système Lime Ø et vous rencontrerez l'idée d'ameublement qui vous correspond le plus, vous voyagerez parmi les compositions, les formes, les lignes, les couleurs, les volumes, les finitions, les matériaux et les pièces. Bon voyage.



Lime Ø/001 pag. 6



Lime Ø/002 pag. 16



Lime Ø/003 pag. 26



Lime Ø/004 pag. 34

Auf den folgenden Seiten können Sie eindringen in eine ausführliche Darstellung der Vielseitigkeit des Systems Lime Ø und beim Reisen durch Kompositionen, Formen, Linien, Farbtöne, Rauminhalte, Finishes, Materialien und Räume die Badezimmeridee finden, die zu Ihnen passt. Gute Aussichten.

LIME Ø

En las páginas a continuación podrán adentrarse en una amplia representación de la versatilidad del sistema Lime Ø y encontrar la idea de decoración del baño que están buscando, viajando entre composiciones, formas, líneas, tonos, volúmenes, acabados, materiales y ambientes. Buena visión.

001 Particolari e dettagli che aggiungono valore alla casa rendono speciale questo bagno con mobile dotato di terminale a giorno / Features and details, which add value to the home, make this bathroom special with an open-plan end unit / Les détails qui valorisent la maison rendent cette salle de bains unique avec le meuble à élément ouvert / Besonderheiten und Details, die das Haus aufwerten, machen dieses Badezimmer mit Möbel mit offenem Abschlusselement zu etwas Besonderem / Piezas particulares y detalles que otorgan valor a la casa haciendo especial este cuarto de baño con mueble equipado con elemento terminal abierto







Questa composizione propone dettagli di grande qualità e design come le maniglie Like e lo specchio Sasso.

This composition features top-quality details and design features such as the Like handle and the Sasso mirror.

Cette composition propose des détails de haute qualité et de grand design comme les poignées Like et le miroir Sasso.



Diese Komposition bietet qualitativ hochwertige Details und Design wie die Griffe Like und der Spiegel Sasso.

Esta composición propone detalles de gran calidad y diseño como los tiradores Like y el espejo Sasso.



I pensili adottano il pratico sistema di apertura push pull. Sotto: particolare della base con lo zoccolo in Alluminio.

The wall cabinets are fitted with a practical push-pull opening system. Below: close-up of the Alluminio plinth.



Les meubles suspendus adoptent le système d'ouverture Push & Pull. Au-dessous: la plinthe en Alluminio.

Die passenden Hängeschränke besitzen das praktische Push&Pull-Öffnungssystem. Unten: Detailansicht des Sockels aus Alluminio.

Los armarios adoptan el sistema de apertura push pull. Debajo: pieza del zócalo de Alluminio.



Caratteristiche tecniche / Technical features / Caractéristiques techniques /
Technische Merkmale / Rasgos técnicos



Dimensioni / Dimensions / Dimensions /
Größe / Dimensiones

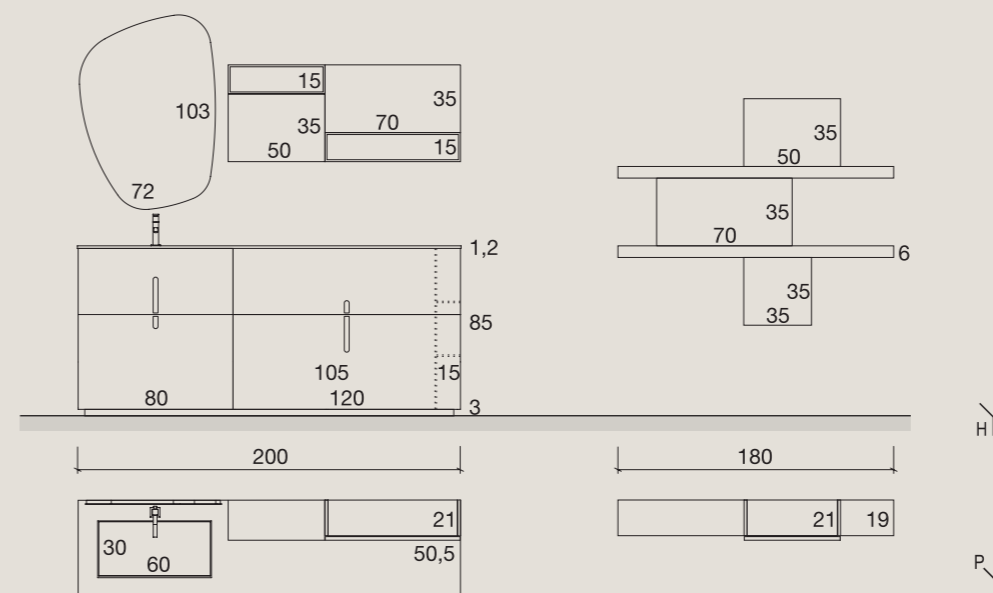

Finiture / Finishes / Finitions /
Oberflächen / Acabados

TOP CON VASCA INTEGRATA RETTANGOLO



TECNORIL BIANCO
COD. TT0

BASI



LACCATO NUANCE CENERE OPACO
COD. 792

PENSILI



LACCATO NEBBIA OPACO
COD. 291

**PENSILI A GIORNO / VANO A
GIORNO LATERALE / MENSOLE**

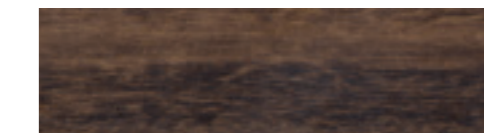

DEKORATIVO 3D
EUCALIPTO SABLÈ TERMOCOTTO
COD. 1SC

- 1 Top Sp. 1,2 cm con vasca integrata Rettangolo L. 60 cm
- 2 Specchiera sagomata Sasso L. 72 H. 103 cm retroilluminata a Led
- 3 Maniglia Like Nickel Satinato Lucido
- 4 Pensili con apertura Push&Pull
- 5 Vano a giorno laterale a terra

- 1 Top Th. 1.2 cm with Rettangolo integrated wash basin W. 60 cm
- 2 Shaped Sasso wall mirror W. 72 H. 103 cm LED backlighting
- 3 Like handle Nickel Satinato Glossy
- 4 Wall units with Push&Pull opening system
- 5 Floor standing unit with open side

- 1 Plan de toilette Ép. 1,2 cm avec vasque intégrée Rettangolo L. 60 cm
- 2 Miroir galbé Sasso L. 72 H. 103 cm rétroéclairé à Led
- 3 Poignée Like Nickel Satinato Brillant
- 4 Éléments suspendus avec ouverture Push&Pull
- 5 Élément ouvert sur le côté au sol

- 1 Waschtischplatte Stärke: 1,2 cm mit eingelassenem Rettangolo Waschbecken B. 60 cm
- 2 Geformter Wandspiegel Sasso B. 72 H. 103 cm von hinten beleuchtet mit LED
- 3 Griff Like Nickel Satinato Glänzend
- 4 Hängeschränke mit Push&Pull-Öffnung
- 5 Offenes seitliches Fach am Boden

- 1 Encimera Esp. 1,2 cm con lavabo integrado Rettangolo A. 60 cm
- 2 Espejo perfilado Sasso A. 72 H. 103 cm retroiluminado con Led
- 3 Tirador Like Nickel Satinato Lustroso
- 4 Colgantes con apertura Push&Pull
- 5 Compartimiento lateral abierto en el suelo

002 La scelta dei materiali, gli elementi e le geometrie suggeriscono un gusto internazionale in un contesto di grande rigore estetico / The choice of materials, elements and shapes lend an international feel to a space with a sober overall look / Le choix des matériaux, les éléments et les géométries suggèrent un goût international au cœur d'une grande rigueur esthétique / Die Auswahl der Materialien, die Elemente und die Geometrien suggerieren einen internationalen Geschmack in einem Kontext großer ästhetischer Strenge / La elección de los materiales, los elementos y las geometrías sugieren un gusto internacional en un contexto de gran precisión estética







La maniglia Fly, in questa composizione, nella versione acciaio spazzolato. Pratica e divertente la combinazione di moduli sospesi.

Der Griff Fly ist in dieser Komposition in der Ausführung gebürsteter Stahl zu sehen. Die Kombination aus Hängemodulen ist praktisch und unterhaltsam.



The Fly handle, in this composition, in the brushed steel version. The combination of wall-mounted units is practical and fun.

El tirador Fly, en esta composición, en la versión acero cepillado. Práctica y divertida la combinación de módulos colgantes.

La poignée Fly, dans cette composition, est proposée dans la version acier finition spatulée. Pratique et amusante la combinaison de modules suspendus.



Una linea di elementi a giorno in finitura Rovere Sherwood Castano unisce due serie di pensili laccati. La maniglia Fly è protagonista in una versione tono su tono.

A line of open elements in a Rovere Sherwood Castano finish bring together two series of lacquered wall units. The Fly handle is a stand-out feature in a tone on tone version.

Une ligne d'éléments ouverts en finition Rovere Sherwood Castano unit deux séries de meubles suspendus laqués. La poignée Fly est protagoniste dans une version ton sur ton.

Eine Reihe offener Elemente im Finish Rovere Sherwood Castano vereint zwei Serien lackierter Hängeschränke. Der Griff Fly ist Hauptakteur in einer Ausführung Ton in Ton.

Una línea de elementos abiertos con acabado Rovere Sherwood Castano une dos series de colgantes lacados. El tirador Fly es protagonista en una versión de combinación de tonos.



Caratteristiche tecniche / Technical features / Caractéristiques techniques /
Technische Merkmale / Rasgos técnicos

Dimensioni / Dimensions / Dimensions /
Größe / Dimensiones

Finiture / Finishes / Finitions /
Oberflächen / Acabados

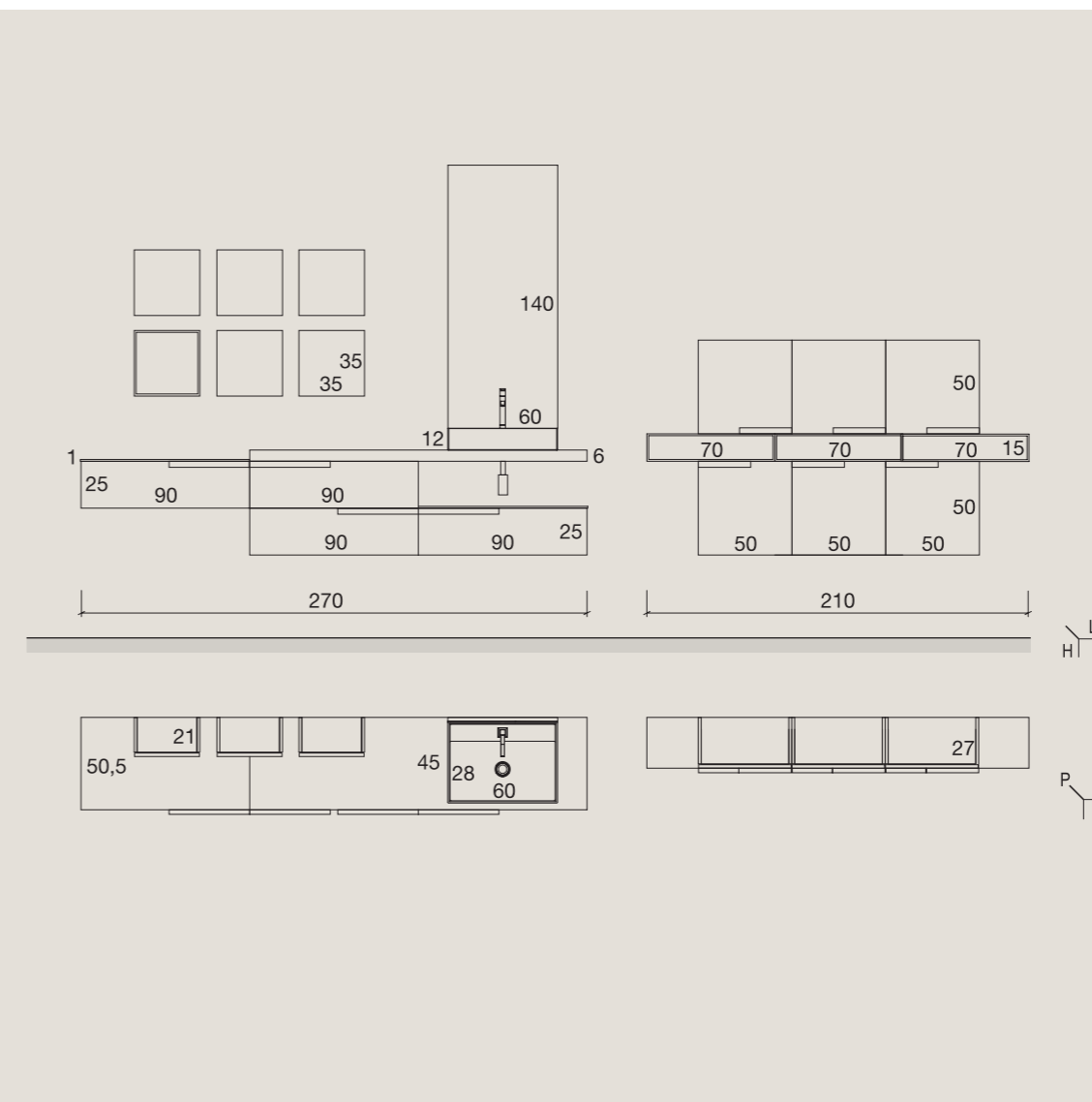

LAVABO TUTTO FUORI ICON 60R



CERAMICA BIANCA

TOP SP. 6 CM / PENSILE A GIORNO



DEKORATIVO 3D
ROVERE SHERWOOD CASTANO
COD. 1S3

BASI / PENSILI

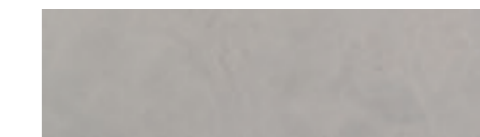

DEKORATIVO 3D
CEMENTO TORTORA
COD. 1A2

PENSILI



LACCATO BLU ARTICO LUCIDO
COD. 337

1 Lavabo Tutto Fuori Icon 60R
(cod. LVEAECF60)

2 Top Sp. 6 cm

3 Specchiera rettangolare
L. 60 H. 140 cm

4 Maniglia Fly acciaio spazzolato
e laccata in tinta

5 Pensili con apertura Push&Pull

1 Icon 60R Sit-on Washbasin
(code LVEAECF60)

2 Top, Th. 6 cm

3 Rectangular wall mirror
W. 60 H. 140 cm

4 Brushed steel Fly handle
and lacquer in matching colour

5 Wall units with Push&Pull
opening system

1 Vasque à poser Icon 60R
(code LVEAECF60)

2 Plan de toilette Ép. 6 cm

3 Miroir rectangulaire
L. 60 H. 140 cm

4 Poignée Fly acier finition spatulée
et laquée de la même couleur.

5 Éléments suspendus avec
ouverture Push&Pull

1 Aufsatzwaschtisch Icon 60R
(Cod. LVEAECF60)

2 Waschtischplatte Stärke: 6 cm

3 Rechteckiger Wandspiegel
B. 60 H. 140 cm

4 Griff Fly gebürsteter Stahl
und einfarbig lackiert

5 Hängeschränke mit Push&Pull-
Öffnung

1 Lavabo Externo Icon 60R
(cód. LVEAECF60)

2 Encimera Esp. 6 cm

3 Espejo rectangular A. 60 H. 140 cm

4 Tirador Fly Acero Cepillado
y lacado del color del mueble

5 Colgantes con apertura Push&Pull

003 Colori e dettagli con sottili richiami all'architettura degli anni '40 si intrecciano con l'attualità estetica in un ambiente unico / Colours and details with subtle hints of 1940s architecture are blended with a modern-day look in a unique setting / Les couleurs et les détails qui rappellent délicatement l'architecture des années 1940 s'enlacent avec l'esthétique actuelle dans une unique pièce / Farben und Details mit sanften Anlehnungen an die Architektur der 40er Jahre verbinden sich mit der ästhetischen Aktualität in einem einzigartigen Ambiente / Colores y detalles con sutiles referencias de la arquitectura de los años '40 se mezclan con la actualidad estética en un ambiente único





Il piano con vasca integrata
Ovale in Tecnoril Bianco segue
il profilo della base in tutta
la lunghezza.

The top with recessed Ovale
basin in Tecnoril Bianco
follows the entire length of
the base unit profile.

Le plan de toilette avec vasque
intégrée Ovale en Tecnoril
Bianco suit le profil de la base
sur toute la longueur.

Die Fläche mit eingelassenem
Waschbecken Ovale aus
Tecnoril Bianco folgt dem
Profil des Unterschranks
auf der ganzen Länge.

La encimera con lavabo
integrado Ovale de Tecnoril
Bianco sigue el perfil de la
base en todo el largo.



Comodi e preziosi i moduli
pensili in Dekorativo 3D Reflex
effetto Metallizzato combinati
in modo irregolare.

The wall units in Dekorativo 3D
Reflex effetto Metallizzato, in
different widths, are practical
and sophisticated.

Pratiques et précieux, les
éléments suspendus en
Dekorativo 3D Reflex effetto
Metallizzato combinés avec
irrégularité.

Die Hängemodule aus
Dekorativo 3D Reflex
effetto Metallizzato sind,
unregelmäßig kombiniert,
bequem und wertvoll.



Cómodos y preciados los
módulos armarios de
Dekorativo 3D Reflex con
effetto Metallizzato combinados
de manera irregular.

Caratteristiche tecniche / Technical features / Caractéristiques techniques /
Technische Merkmale / Rasgos técnicos

Dimensioni / Dimensions / Dimensions /
Größe / Dimensiones

Finiture / Finishes / Finitions /
Oberflächen / Acabados

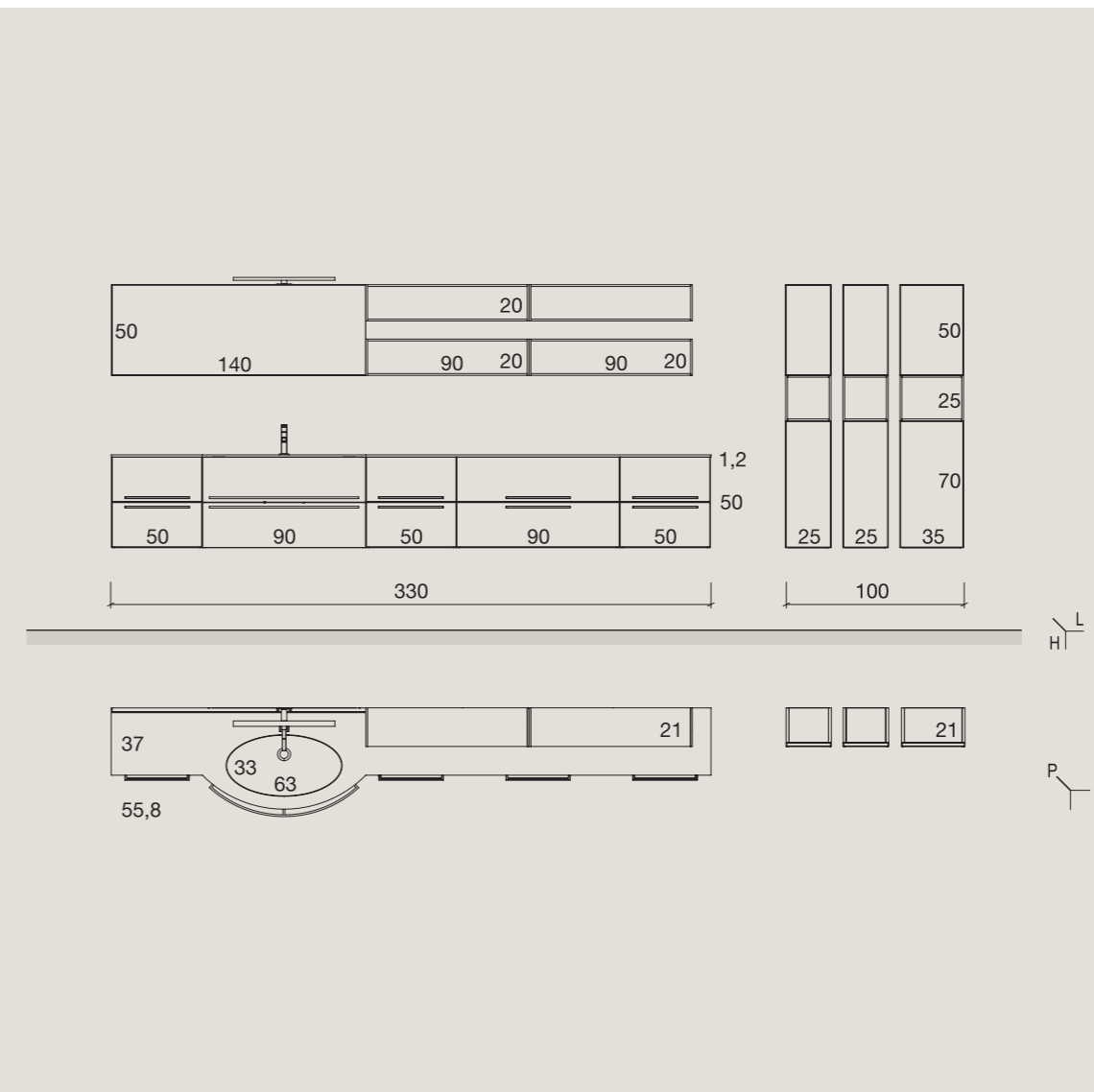

TOP CON VASCA INTEGRATA OVALE



TECNORIL BIANCO
COD. TT0

BASI / COLONNE



DEKORATIVO 3D
SHERWOOD SCURO
COD. 1S2

PENSILI A GIORNO



DEKORATIVO 3D
REFLEX EFFETTO METALLIZZATO
COD. 1RE

- 1 Top Sp. 1,2 cm con vasca integrata
Ovale L. 63 cm
- 2 Specchiera rettangolare
L. 140 H. 50 cm
- 3 Lampada Led Win Tre
(cod. LPW3050)
- 4 Maniglia Stilo Cromo

- 1 Top Th. 1.2 cm with recessed
Ovale basin W. 63 cm
- 2 Rectangular wall mirror
W. 140 H. 50 cm
- 3 Win Tre LED light (code LPW3050)
- 4 Chrome-plated Stilo handle

- 1 Plan de toilette Ép. 1,2 cm avec
vasque intégrée Ovale L. 63 cm
- 2 Miroir rectangulaire
L. 140 H. 50 cm
- 3 Lampe à Led Win Tre (code
LPW3050)
- 4 Poignée Stilo chromée

- 1 Waschtischplatte Stärke: 1,2 cm
mit eingelassenem Waschbecken
Ovale B. 63 cm
- 2 Rechteckiger Wandspiegel
B.140 H.50 cm
- 3 LED-Lampe Win Tre
(Cod. LPW3050)
- 4 Griff Stilo Chrom

- 1 Encimera Esp. 1,2 cm con lavabo
integrado Ovale A. 63 cm
- 2 Espejo rectangular A. 140 H. 50 cm
- 3 Lámpara Led Win Tre (cód.
LPW3050)
- 4 Tirador Stilo Cromo

004 Perché accontentarsi di una casa standard quando possiamo creare ambienti come questo? Uno spazio capace di comunicare lusso ed emozione / Why settle for a conventional home when we can create rooms like this? A space that transmits a sense of luxury and emotion / Pourquoi se contenter d'une maison banale quand on peut réaliser des pièces comme celles-ci ? Un espace en mesure de communiquer le luxe et l'émotion / Warum sich mit einem Standardhaus zufrieden geben, wenn wir Ambiente wie dieses kreieren können? Ein Raum, der in der Lage ist, Luxus und Emotion zu kommunizieren / ¿Por qué conformarse con una casa estándar cuando podemos crear ambientes como este? Un espacio que comunica lujo y emoción







Un tocco luxury con top e alzatina in Gres Porcellanato lucido Cava Noir Desir e vasca integrata Scivolo. Elementi pensili interamente in vetro.

A touch of luxury with top and splashback in Gres Porcellanato glossy Cava Noir Desir and Scivolo recessed basin. All-glass wall elements.

Une touche luxury avec plan de toilette et dossier en Gres Porcellanato brillant Cava Noir Desir avec vasquée intégrée Scivolo. Les éléments suspendus en verre.



Ein Hauch Luxus mit Waschtischplatte und Abschlussprofil aus Gres Porcellanato glänzend Cava Noir Desir und Waschbeken Scivolo. Hängeelemente, die vollständig aus Glas sind.

Un toque luxury con mesada y contrahuella de Gres Porcellanato lustroso Cava Noir Desir y lavabo integrado Scivolo. Elementos de armarios completamente de vidrio.



Variante con top e vasca
integrata Cover in Gres
Porcellanato Fokos Roccia.

—
Variation with top and Cover
recessed basin in Gres
Porcellanato Fokos Roccia.

—
Version avec plan de toilette
et vasque intégrée Cover
en Gres Porcellanato Fokos
Roccia.

Variante mit Waschtischplatte
und eingelassenem Cover
Waschbecken aus Gres
Porcellanato Fokos Roccia.

—
Variante con encimera y
lavabo integrado Cover de
Gres Porcellanato Fokos
Roccia.

Caratteristiche tecniche / Technical features / Caractéristiques techniques /
Technische Merkmale / Rasgos técnicos

Dimensioni / Dimensions / Dimensions /
Größe / Dimensiones

Finiture / Finishes / Finitions /
Oberflächen / Acabados

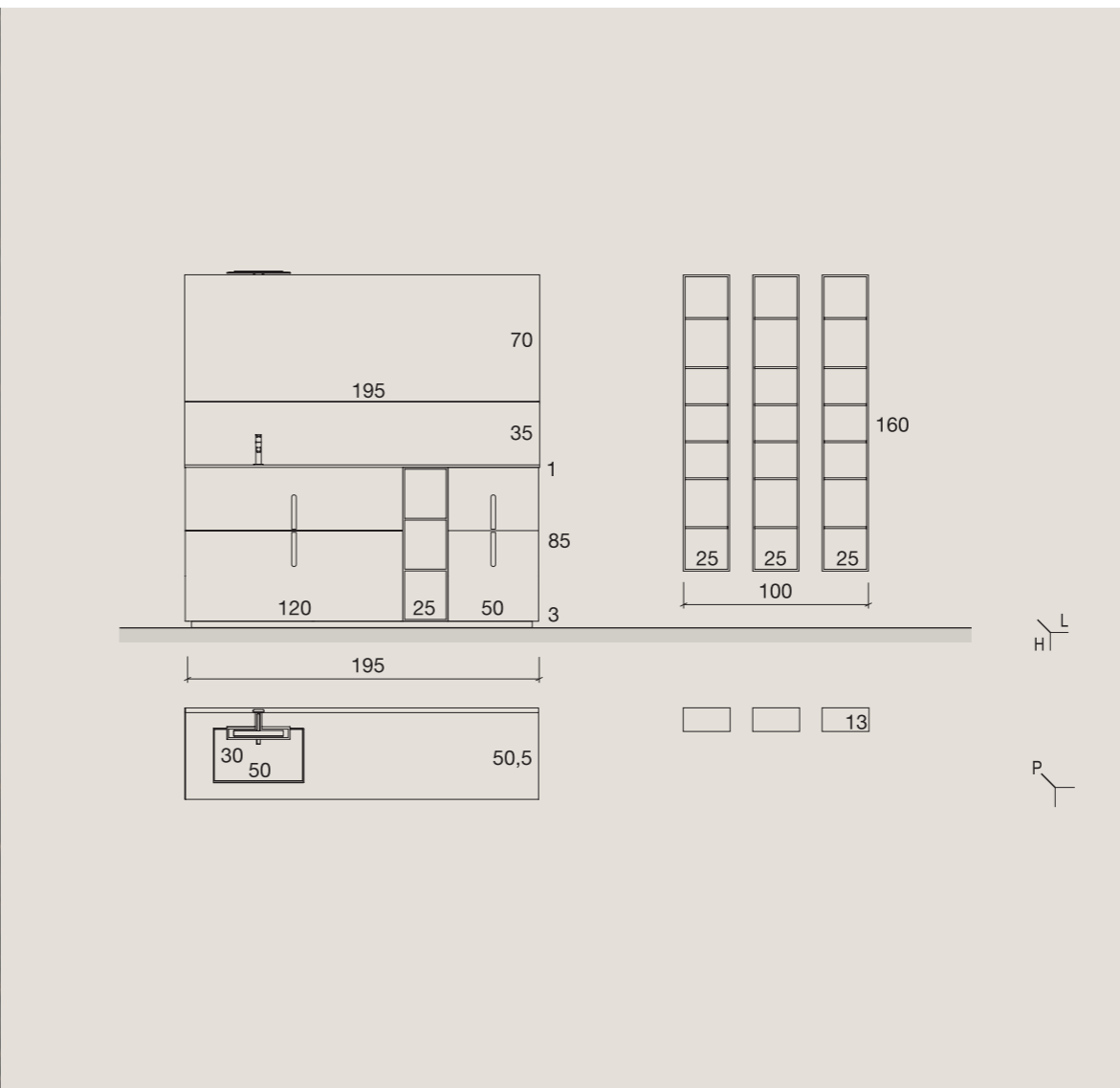

**TOP CON VASCA INTEGRATA SCIVOLO /
ALZATINA**

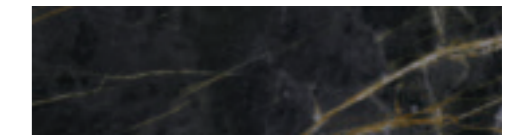

GRES PORCELLANATO
CAVA NOIR DESIR LUCIDO
COD. TQJ

BASI

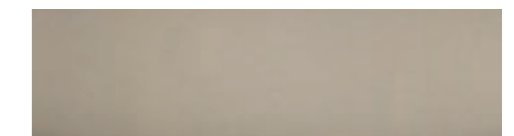

LACCATO
CRETA METALLIZZATO LUCIDO
COD. 3M6

**BASE A GIORNO / SCHIENALE
PENSILI VETRO**

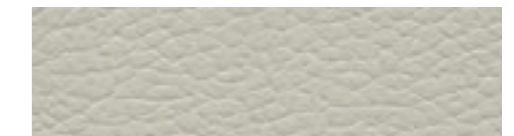

DEKORATIVO 3D
PRIMO FIORE EFFETTO PELLE CANAPA
COD. 1PC

- 1 Top Sp. 1 cm con vasca integrata Scivolo L. 50 cm
- 2 Specchiera rettangolare L. 195 H. 70 cm
- 3 Lampada Led Short (cod. LPSH034)
- 4 Maniglia Like Titanio

- 1 Top Th. 1 cm with Scivolo recessed basin W. 50 cm
- 2 Rectangular wall mirror W. 195 H. 70 cm
- 3 Short LED light (code LPSH034)
- 4 Titanio Like handle

- 1 Plan de toilette ép. 1 cm avec vasque intégrée Scivolo L. 50 cm
- 2 Miroir rectangulaire L.195 H.70 cm
- 3 Lampe à Led Short (code LPSH034)
- 4 Poignée Like Titanio

- 1 Waschtischplatte mit einer Stärke von 1 cm mit eingelassenem Waschbecken Scivolo B. 50 cm
- 2 Rechteckiger Wandspiegel B. 195 H. 70 cm
- 3 LED-Lampe Short (Cod. LPSH034)
- 4 Griff Like Titanio

- 1 Encimera Esp. 1 cm con lavabo integrado Scivolo A. 50 cm
- 2 Espejo rectangular A. 195 H. 70 cm
- 3 Lámpara de Led Short (cód. LPSH034)
- 4 Tirador Like Titanio

Variante

**TOP CON VASCA INTEGRATA COVER /
ALZATINA**

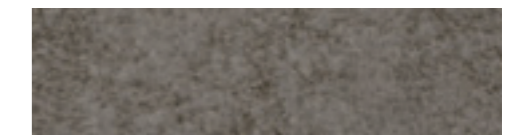

GRES PORCELLANATO
FOKOS ROCCIA
COD. TQ3

005 Segni e materiali che si incontrano in un ambiente forte e delicato insieme. Su tutto, il fine pendant tra specchiera e maniglia / Features and materials merge in a strong, yet delicate setting. Completed by the subtly matched mirror and handle / Des détails et des matériaux qui se mélangent dans une pièce à la fois intense et délicate. Sur tout, le pendant entre le miroir et la poignée / Zeichen und Materialien, die sich in einem Raum treffen, der gleichzeitig stark und empfindlich ist. Bei allem das feine Pendant zwischen Spiegel und Griff / Diseños y materiales conviven juntos en un ambiente fuerte y delicado. Se destaca, la combinación entre espejo y tirador







Frontali e mobile in Dekorativo 3D con finitura Nodato Spaccato Biondo e top in Ocritech con vasca integrata Oly, in elegante contrasto con la parete. Dettaglio della maniglia Sasso.

Front panels and unit in Dekorativo 3D with Nodato Spaccato Biondo finish and Ocritech top with Oly recessed washbasin, creating an elegant contrast with the wall. Close-up of the Sasso handle.

Façades et meuble en Dekorativo 3D avec finition Nodato Spaccato Biondo et plan de toilette en Ocritech avec vasque intégrée Oly, en contraste élégant avec le mur. Vue détaillée de la poignée Sasso.

Fronten und Möbel aus Dekorativo 3D mit Finish Nodato Spaccato Biondo und Waschtischplatte aus Ocritech mit eingelassenem Waschbecken Oly, in einem eleganten Kontrast mit der Wand. Detailansicht des Griffs Sasso.

Elementos frontales y muebles en Dekorativo 3D con acabado Nodato Spaccato Biondo y encimera de Ocritech con lavabo integrado Oly, en contraste elegante con la pared. Detalle del tirador Sasso.



Caratteristiche tecniche / Technical features / Caractéristiques techniques /
Technische Merkmale / Rasgos técnicos



Dimensioni / Dimensions / Dimensions /
Größe / Dimensiones

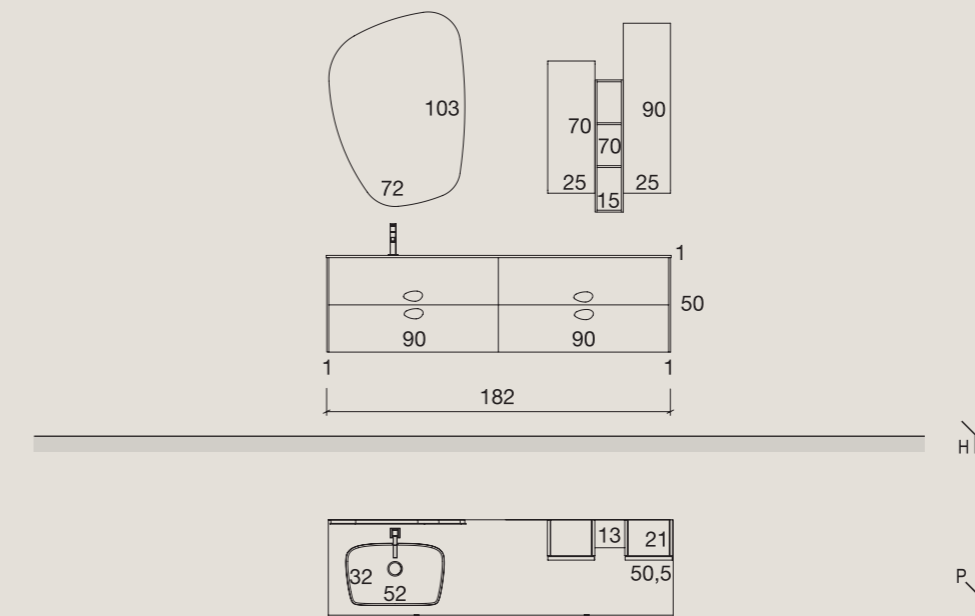

Finiture / Finishes / Finitions /
Oberflächen / Acabados

TOP CON VASCA INTEGRATA OLY



OCRITECH
BIANCO OPACO
COD. TD1

BASI / PENSILE A GIORNO



DEKORATIVO 3D
NODATO SPACCATO BIONDO
COD. 1NA

PENSILI



LACCATO BIANCO OPACO
COD. 20B

1 Top Sp. 1 cm con vasca integrata
Oly L. 52 cm

2 Specchiera sagomata Sasso
L. 72 H. 103 cm retroilluminata
a Led

3 Maniglia Sasso Bianco

4 Pensili con apertura Push&Pull

1 Top Th. 1 cm with Oly recessed
basin W. 52 cm

2 Shaped Sasso wall mirror
W. 72 H. 103 cm LED
backlighting

3 Bianco Sasso handle

4 Wall units with Push&Pull
opening system

1 Plan de toilette Ép. 1 cm avec vasque
intégrée Oly L. 52 cm

2 Miroir galbé Sasso L. 72 H. 103 cm
rétroéclairé à Led

3 Poignée Sasso Bianco

4 Éléments suspendus avec ouverture
Push&Pull

1 Waschtischplatte Stärke:1 cm
mit eingelassenem Waschbecken
Oly B. 52 cm

2 Geformter Wandspiegel Sasso
B. 72 H. 103 cm von hinten
beleuchtet mit LED

3 Griff Sasso Bianco

4 Hängeschränke mit Push&Pull-
Öffnung

1 Encimera Esp.1 cm con lavabo
integrado Oly A. 52 cm

2 Espejo perfilado Sasso
A. 72 H. 103 cm retroiluminado
a LED

3 Tirador Sasso Bianco

4 Colgantes con apertura Push&Pull

006 La tecnologia non ha più limiti e ci regala la possibilità di scegliere dettagli unici, come quelli di questo bagno dal gusto prezioso / Technology knows no limits and gives us the opportunity to choose unique details, such as the ones in this sophisticated bathroom / La technologie n'a plus de limites et nous offre possibilité de choisir des détails uniques comme ceux de cette salle de bains au goût précieux / Die Technologie hat keine Grenzen mehr und schenkt uns die Möglichkeit einzigartige Details zu wählen, wie die dieses Badezimmers mit kostbarem Stil / La tecnología no tiene más límites y nos regala la posibilidad de elegir detalles únicos, como los de este baño de gustopreciado







Anche la mensola è in HPL Unicolor Rovere Monet come le basi e la vasca integrata Scivolo.

The shelf is also in HPL Unicolor Rovere Monet, as are the base units and the Scivolo recessed basin.

L'étagère est en HPL Unicolor Rovere Monet tout comme les éléments bas et la vasque intégrée Scivolo.

Auch die Ablage ist aus HPL Unicolor Rovere Monet wie die Unterschränke und das Waschbecken Scivolo.

También el estante es de HPL Unicolor Rovere Monet como los muebles y el lavabo integrado Scivolo.



Il segno pulito della maniglia Like firma con un tocco di design i frontali del mobile bagno.

The clean lines of the Like handle add a designer touch to the doors of the bathroom unit.

Le trait net de la poignée Like ajoute une touche de design aux portes du meuble.



Die klare Linie des Griffs Like signiert die Türen des Badezimmermöbels mit einem Touch von Design.

La línea sobria del tirador Like firma con un toque de diseño las puertas del mueble del baño.

Caratteristiche tecniche / Technical features / Caractéristiques techniques /
Technische Merkmale / Rasgos técnicos



Dimensioni / Dimensions / Dimensions /
Größe / Dimensiones

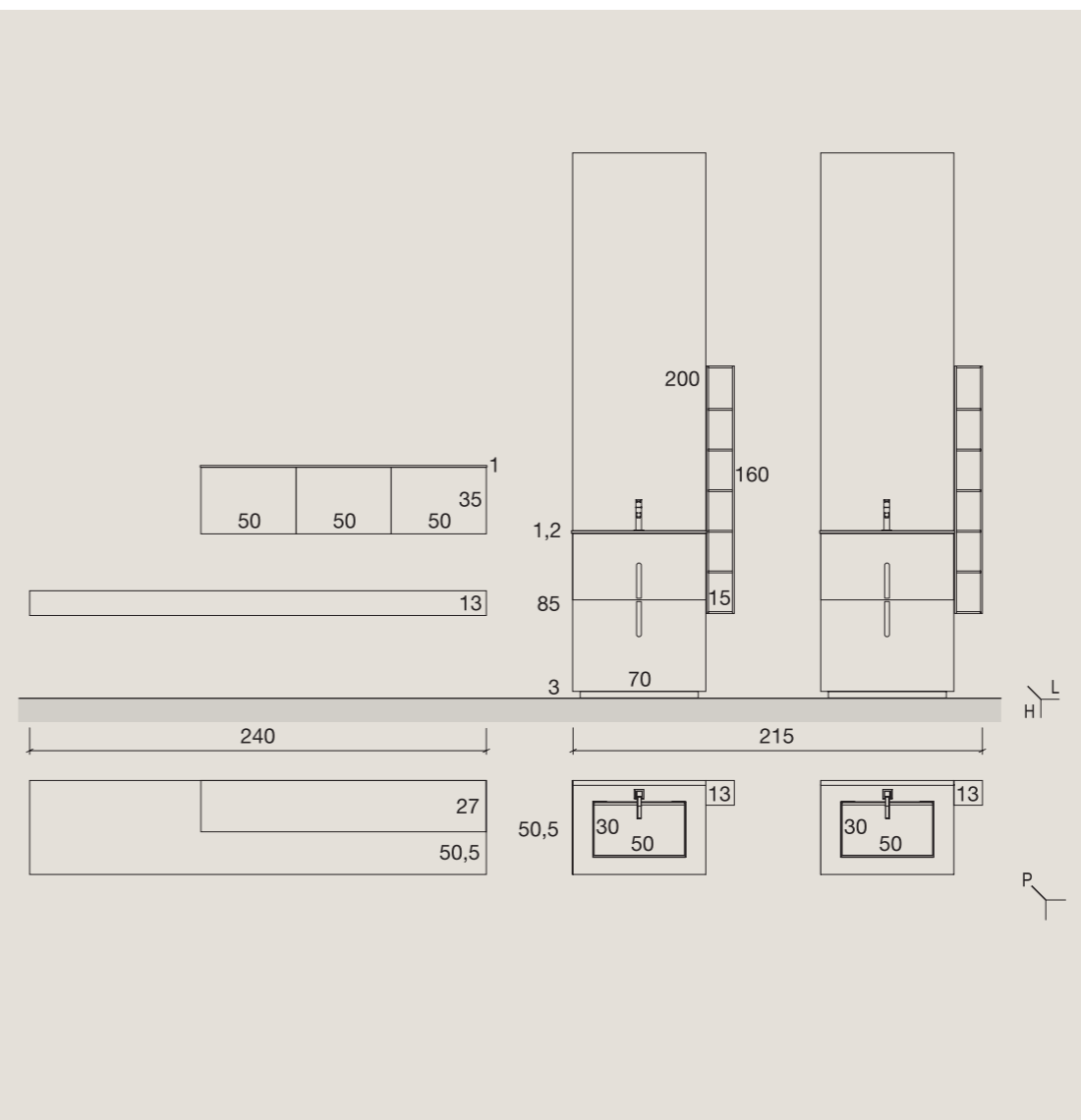

Finiture / Finishes / Finitions /
Oberflächen / Acabados

**TOP CON VASCA INTEGRATA
SCIVOLO / BASI / MENSOLA**



HPL UNICOLOR
ROVERE MONET
COD. TK3

COLONNE A GIORNO

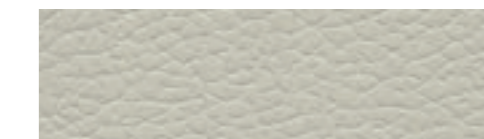

DEKORATIVO 3D
PRIMO FIORE EFFETTO PELLE CANAPA
COD. 1PC

PENSILI



LACCATO CAPPUCCINO OPACO
COD. 288

1 Top Sp. 1,2 cm con vasca integrata
Scivolo L. 50 cm

2 Specchiera rettangolare
L. 70 H. 200 cm

3 Maniglia Like Nickel Satinato
Lucido

1 Top Th. 1.2 cm with Scivolo
recessed basin W. 50 cm

2 Rectangular wall mirror
W. 70 H. 200 cm

3 Like handle Nickel Satinato
Glossy

1 Plan de toilette Ép. 1,2 cm avec
vasque intégrée Scivolo L. 50 cm

2 Miroir rectangulaire L. 70 H. 200 cm

3 Poignée Like Nickel Satinato
Brillant

1 Waschtischplatte Stärke: 1,2 cm
mit eingelassenem Waschbecken
Scivolo B. 50 cm

2 Rechteckiger Wandspiegel
B. 70 H. 200 cm

3 Griff Like Nickel Satinato
Glänzend

1 Encimera Esp. 1,2 cm con
lavabo integrado en forma de
Scivolo A. 50 cm

2 Espejo rectangular A. 70 H. 200 cm

3 Tirador Like Nickel Satinato
Lustroso

007 Si presenta come una scultura moderna il mobile con piano in Ocritech e maniglia nello stesso tono pastello. Gli elementi sospesi impreziosiscono l'insieme con finiture e geometrie / The unit with the top in Ocritech and handle in matching pastel shade has the look of a modern sculpture. The wall-mounted elements lend a touch of elegance with the finishes and shapes / Telle une sculpture moderne, le meuble avec plan de toilette en Ocritech et poignée de la même couleur pastel. Les éléments suspendus ornent l'ensemble avec leurs finitions et leurs géométries / Das Möbel mit Waschfläche in Ocritech und Griff im selben Pastellton präsentiert sich als moderne Skulptur. Die Hängeelemente bereichern das Ganze mit Finishs und Formen / El mueble se presenta como una escultura moderna con tabla de Ocritech y tirador del mismo tono pastel. Los elementos colgantes embellecen el ambiente con acabados y geometrías







Dettaglio della maniglia
Simple laccata Cenere
come l'intero frontale,
piano top in Ocritech con
vasca Oly esclusiva Azzurra.

Close-up of the Simple
handle with Cenere lacquer
finish, matching the front
panel, Ocritech top with
an exclusive Azzurra
Oly washbasin.

Vue en détail de la poignée
Simple laquée Cenere
comme toute la façade,
plan de toilette en Ocritech
avec vasque Oly exclusive
Azzurra.

Detailansicht des Griffs
Simple lackiert Cenere
wie die gesamte Front,
Waschtischplatte aus
Ocritech mit exklusivem
Oly Waschbecken Azzurra.

Detalle del tirador
Simple lacado Cenere
como todo el frente,
mesada de la encimera
de Ocritech con lavabo
Oly exclusivo de Azzurra.

Caratteristiche tecniche / Technical features / Caractéristiques techniques /
Technische Merkmale / Rasgos técnicos



Dimensioni / Dimensions / Dimensions /
Größe / Dimensiones

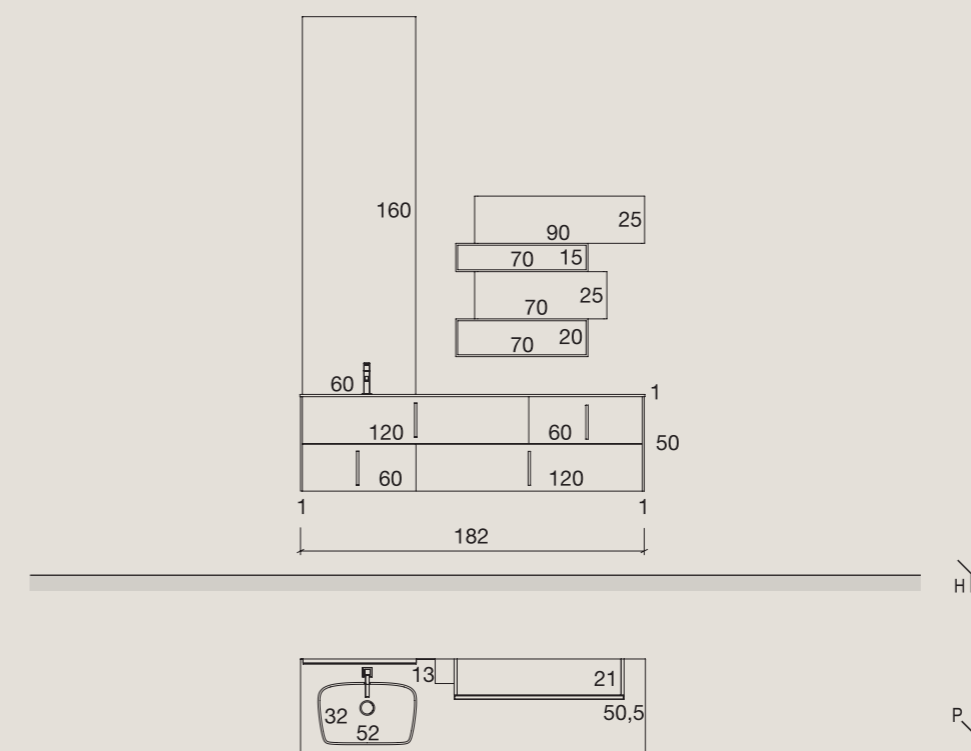

Finiture / Finishes / Finitions /
Oberflächen / Acabados

TOP CON VASCA INTEGRATA OLY



OCRITECH
BIANCO OPACO
COD. TD1

BASI



LACCATO NEBBIA OPACO
COD. 291

PENSILI



LACCATO BIANCO OPACO
COD. 20B

PENSILI A GIORNO



DEKORATIVO 3D
NODATO SPACCATO BIONDO
COD. 1NA

- 1 Top Sp. 1 cm con vasca integrata Oly L. 52 cm
- 2 Specchiera rettangolare L. 60 H. 160 cm
- 3 Maniglia Simple laccata in tinta
- 4 Pensili con apertura Push&Pull

- 1 Top Th. 1 cm with Oly recessed washbasin W. 52 cm
- 2 Rectangular wall mirror W. 60 H. 160 cm
- 3 Simple handle in matching lacquer finish
- 4 Wall units with Push&Pull opening system

- 1 Plan de toilette Ép. 1 cm avec vasque intégrée Oly L. 52 cm
- 2 Miroir rectangulaire L. 60 H. 160 cm
- 3 Poignée Simple laquée de la même couleur
- 4 Éléments suspendus avec ouverture Push&Pull

- 1 Waschtischplatte Stärke: 1 cm mit eingelassenem Waschbecken Oly B. 52 cm
- 2 Rechteckiger Wandspiegel B. 60 H. 160 cm
- 3 Griff Simple lackiert einfarbig
- 4 Hängeschränke mit Push&Pull-Öffnung

- 1 Encimera Esp. 1 cm con lavabo integrado Oly A. 52 cm
- 2 Espejo rectangular A. 60 H. 160 cm
- 3 Tirador Simple lacado del color del mueble
- 4 Armarios con apertura Push&Pull

008 Due superfici diverse al tatto e alla vista, un mondo materico dai forti contrasti. La ricerca della bellezza è un percorso intrigante / Two different tactile and visual surfaces, a world of strongly contrasting textures. The quest for beauty is a full of surprises / Deux surfaces au toucher et à la vue différents un monde matérique aux contrastes importants. La recherche de la beauté est un parcours intrigant / Zwei Oberflächen, die sich unterschiedlich anfühlen und aussehen, eine stoffliche Welt mit starken Kontrasten. Die Suche nach der Schönheit ist ein faszinierender Weg / Dos superficies diferentes al tacto y a la vista, un mundo de materiales de fuertes contrastes. La búsqueda de la belleza es un itinerario intrigante







Una ricchezza accogliente e protettiva in un ambiente lussuoso e affascinante, da vivere ogni giorno.

A welcoming, cocooned atmosphere in a glamorous, luxurious setting, to be enjoyed every day.

Une richesse accueillante et protectrice dans une pièce luxueuse et séduisante, à vivre pleinement chaque jour.

Eine einladende und schützende Fülle in einem luxuriösen und faszinierenden Ambiente für jeden Tag.

Una riqueza acogedora y protectora en un ambiente de lujo y encantador, para vivir cotidianamente.



Il pregio dei cassetti a profilo curvo si combina con il top in Mineralmarmo Calce Tortora con vasca integrata Tivi esclusiva Azzurra.

The elegance of the curved lines of the drawers is combined with the Mineralmarble Calce Tortora top and an exclusive Azzurra Tivi recessed basin.

La qualité des tiroirs au profil arrondi se marie avec le plan de toilette en Mineralmarbre Calce Tortora avec vasque intégrée Tivi exclusive Azzurra.



Der Vorzug der Schubladen mit geschwungenem Profil kombiniert mit der Waschtischplatte aus Mineralmarmo Calce Tortora mit eingelassenem exklusivem Tivi Waschbecken Azzurra.

La cualidad de los cajones con perfil curvo se combina con la encimera de Mineralmarmo Calce Tortora con lavabo integrado Tivi exclusivo de Azzurra.



Caratteristiche tecniche / Technical features / Caractéristiques techniques /
Technische Merkmale / Rasgos técnicos

Dimensioni / Dimensions / Dimensions /
Größe / Dimensiones

Finiture / Finishes / Finitions /
Oberflächen / Acabados

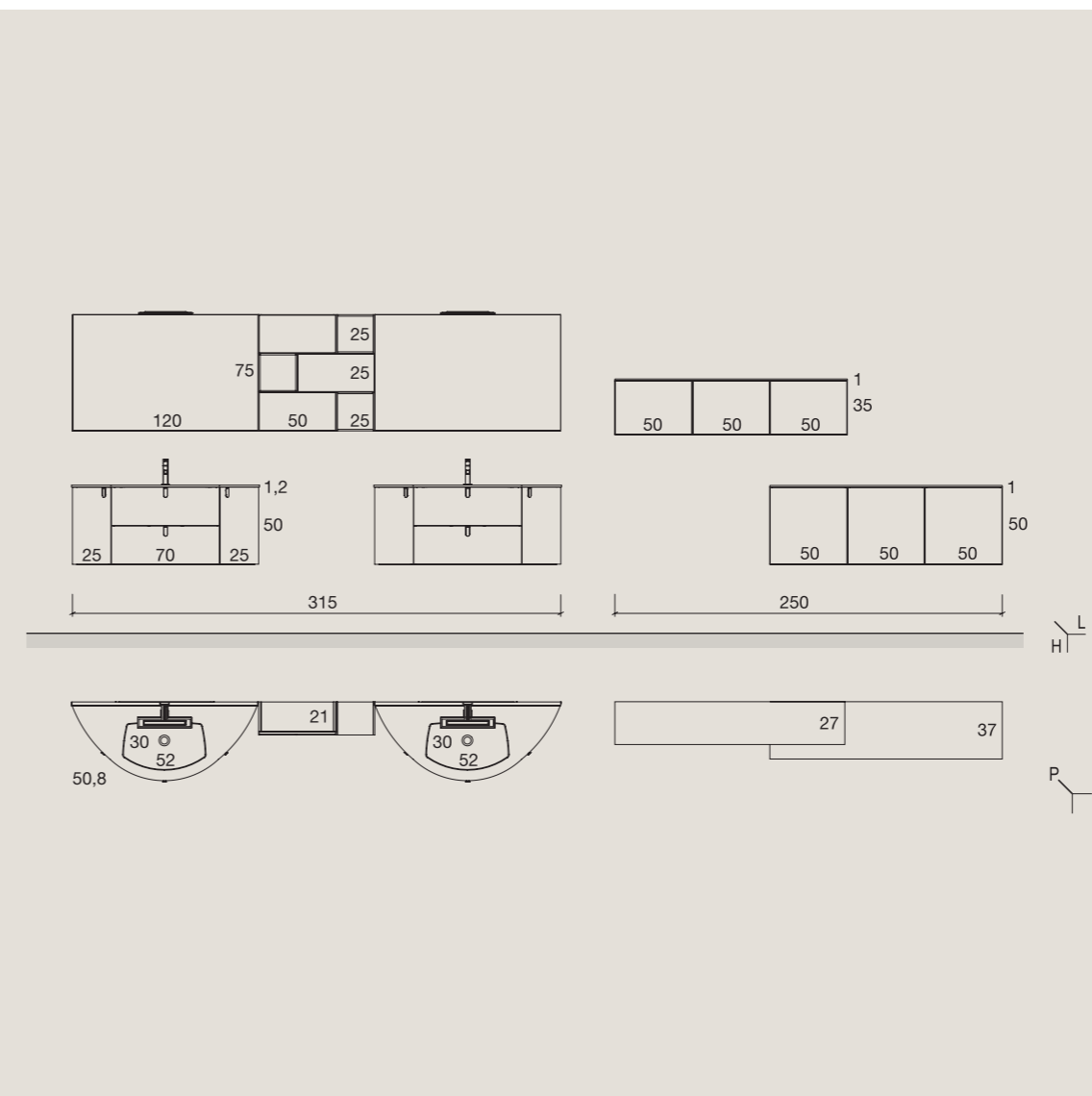

TOP CON VASCA INTEGRATA TIVI



MINERALMARMO CALCE
TORTORA
COD. TAC

BASI / PENSILI



LACCATO GRIGIO GRAFITE LUCIDO
COD. 302

BASI / PENSILI A GIORNO

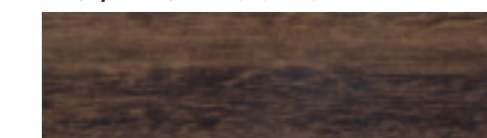

DEKORATIVO 3D
EUCALIPTO SABLÈ TERMOCOTTO
COD. 1SC

- 1 Top Sp. 1,2 cm con vasca integrata Tivi L. 52 cm
- 2 Specchiera rettangolare L. 120 H. 75 cm
- 3 Lampada Led Slim (cod. LPSL035)
- 4 Maniglia Like Cromo
- 5 Pensili con apertura Push&Pull

- 1 Top Th. 1.2 cm with Tivi recessed basin W. 52 cm
- 2 Rectangular wall mirror W. 120 H. 75 cm
- 3 Slim LED light (code LPSL035)
- 4 Chrome-plated Like handle
- 5 Wall units with Push&Pull opening system

- 1 Plan de toilette ép. 1,2 cm avec vasque intégrée Tivi L. 52 cm
- 2 Miroir rectangulaire L. 120 H. 75 cm
- 3 Lampe à Led Slim (code LPSL035)
- 4 Poignée Like chromée
- 5 Éléments suspendus avec ouverture Push&Pull

- 1 Waschtischplatte Stärke: 1,2 cm mit eingelassenem Waschbecken Tivi B. 52 cm
- 2 Rechteckiger Wandspiegel B. 120 H. 75 cm
- 3 LED-Lampe Slim (Cod. LPSL035)
- 4 Griff Like Cromo
- 5 Hängeschränke mit Push&Pull-Öffnung

- 1 Encimera Esp. 1,2 cm con lavabo integrado Tivi A. 52 cm
- 2 Espejo rectangular A. 120 H. 75 cm
- 3 Lámpara Led Slim (cód. LPSL035)
- 4 Tirador Like Cromo
- 5 Armarios con apertura Push&Pull



009 Una composizione che crea un'atmosfera sofisticata offrendo spazio e funzionalità ad ogni esigenza che l'ambiente bagno deve soddisfare / A composition that creates a sophisticated atmosphere, fulfilling the need for space and functionality which every bathroom should offer / Une composition qui offre une atmosphère sophistiquée et un espace et une fonctionnalité aux exigences que la salle de bains doit satisfaire / Eine Komposition, die eine raffinierte Atmosphäre schafft und Raum und Funktionalität für alle Ansprüche bietet, die das Badezimmer erfüllen muss / Una composición que crea una atmósfera sofisticada ofreciendo espacio y funcionalidad a cada una de las exigencias que el ambiente del baño debe satisfacer





Colori e geometrie di ispirazione orientale rendono intimo e affascinante questo ambiente caratterizzato dal segno della maniglia Fly, laccata come il frontale in Grigio Grafite opaco.

Oriental inspired colours and shapes make this setting intimate and intriguing, featuring the signature Fly handle, with a lacquer finish matching the matt Grigio Grafite door front.

Les couleurs et les géométries à l'inspiration orientale rendent intime et fascinante cette pièce caractérisée par le design de la poignée Fly, laquée comme la façade en Grigio Grafite mat.



Die Farben und Formen orientalischer Inspiration machen dieses Ambiente, das durch den Griff Fly gekennzeichnet ist, der wie die Front in Grigio Grafite matt lackiert ist, zu etwas intimen und faszinierenden.

Colores y geometrías de inspiración oriental hacen íntimo y encantador este ambiente caracterizado por la línea del tirador Fly, lacado como el frente Grigio Grafite opaco.





Di grande effetto il top in HPL Unicolor Quercia Grigia con vasca integrata Scivolo disponibile anche in Tecnoril Bianco.

The visual impact of the top in HPL Unicolor Quercia Grigia with Scivolo recessed basin is striking. Also available in Tecnoril Bianco.

Époustouflant, le plan de toilette en HPL Unicolor Quercia Grigia avec vasque intégrée Scivolo disponible aussi en Tecnoril Bianco.

Wirkungsvolle Waschtischplatte aus HPL Unicolor Quercia Grigia mit eingelassenem Waschbecken Scivolo. Erhältlich auch in Tecnoril Bianco.

La encimera de HPL Unicolor Quercia Grigia con lavabo integrado Scivolo disponible también en Tecnoril Bianco.

Caratteristiche tecniche / Technical features / Caractéristiques techniques /
Technische Merkmale / Rasgos técnicos



Dimensioni / Dimensions / Dimensions /
Größe / Dimensiones

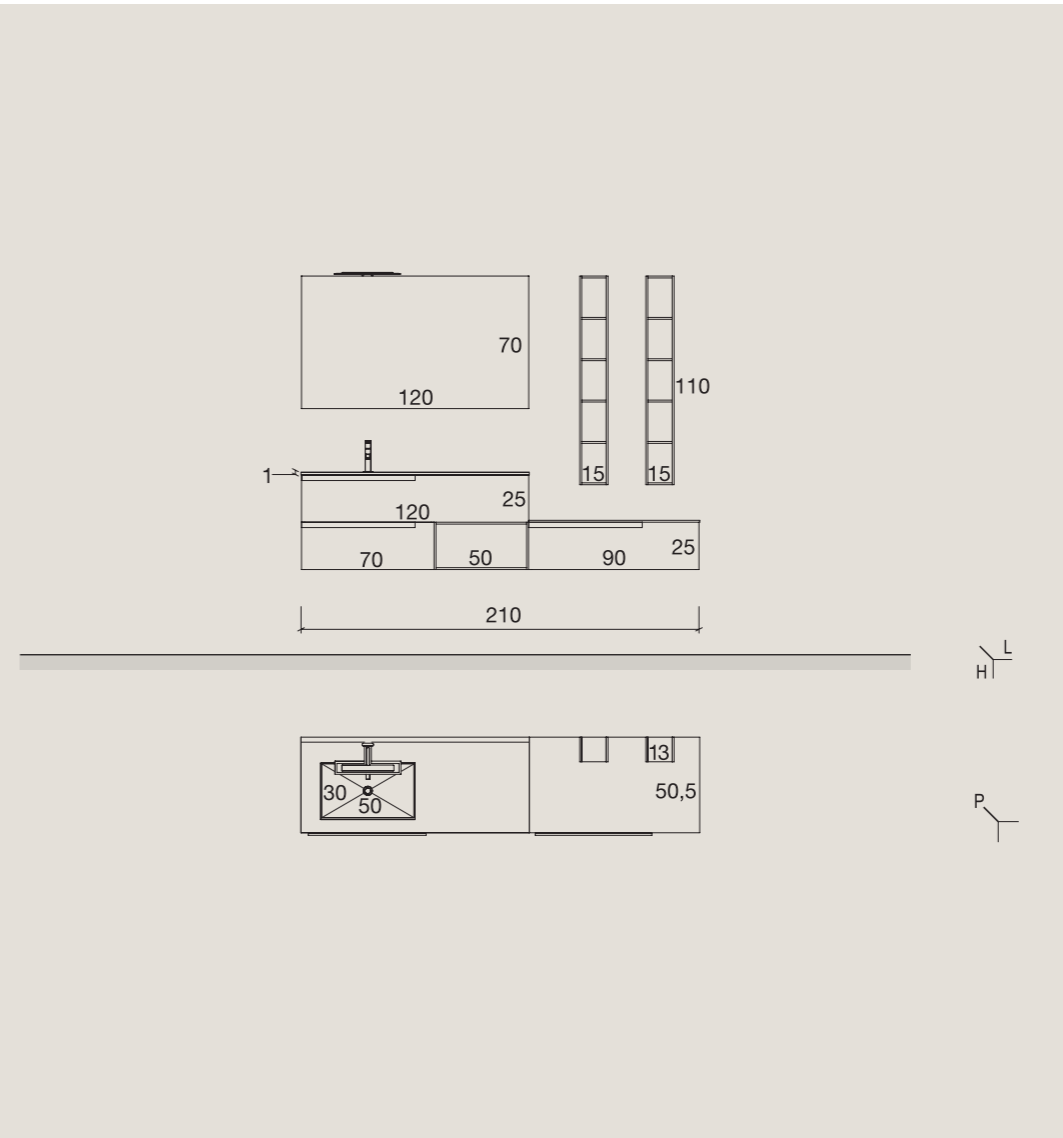

Finiture / Finishes / Finitions /
Oberflächen / Acabados

TOP CON VASCA INTEGRATA PRISMA

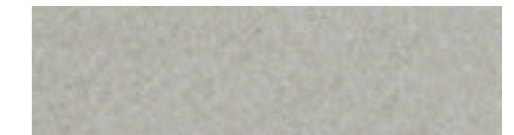

GRES PORCELLANATO
CALCE GRIGIO
COD. TQL

BASI



LACCATO GRIGIO GRAFITE OPACO
COD. 202

BASE A GIORNO / PENSILI A GIORNO



DEKORATIVO 3D
REFLEX EFFETTO METALLIZZATO
COD. 1RE

- 1 Top Sp. 1 cm con vasca integrata Prisma L. 50 cm
- 2 Specchiera rettangolare L. 120 H. 70 cm
- 3 Lampada Led Slim (cod. LPSL035)
- 4 Maniglia Fly laccata in tinta
- 5 Base a giorno e pensili a giorno in Dekorativo 3D

- 1 Top Th.1 cm with integrated Prisma wash basin W. 50 cm
- 2 Rectangular wall mirror W. 120 H. 70 cm
- 3 Slim LED light (code LPSL035)
- 4 Fly handle in matching lacquer finish
- 5 Open base unit and open wall units in Dekorativo 3D

- 1 Plan de toilette Ép. 1 cm avec vasque intégrée Prisma L. 50 cm
- 2 Miroir rectangulaire L. 120 H. 70 cm
- 3 Lampe à Led Slim (code LPSL035)
- 4 Poignée Fly laquée de la même couleur
- 5 Éléments bas ouverts et éléments suspendus ouverts en Dekorativo 3D

- 1 Waschtischplatte Stärke: 1 cm mit eingelassenem Waschbecken Prisma B. 50 cm
- 2 Rechteckiger Wandspiegel B. 120 H. 70 cm
- 3 LED-Lampe Slim (Cod. LPSL035)
- 4 Griff Fly lackiert einfarbig
- 5 Offener Unterschrank und offene Hängeschränke aus Dekorativo 3D

- 1 Encimera Esp. 1 cm con lavabo integrado Prisma A. 50 cm
- 2 Espejo rectangular A. 120 H. 70 cm
- 3 Lámpara de Led Slim (cód. LPSL035)
- 4 Tirador Fly lacado del color del mueble
- 5 Mueble y armarios abiertos en Dekorativo 3D

Variante

TOP CON VASCA INTEGRATA SCIVOLO



HPL UNICOLOR
QUERCIA GRIGIA
COD. TK4

DISPONIBILE ANCHE CON VASCA INTEGRATA SCIVOLO IN TECNORIL BIANCO OPACO
COD. TT0

010 Linee orizzontali, il rigore del bianco, la freschezza del legno chiaro, volumi diversi chiusi e a giorno. Benvenuti in un bagno dove vivere e ricaricarsi / Horizontal lines, the crispness of white, the freshness of light wood, plus a combination of closed and open-plan units. Welcome to a bathroom where you can relax and recharge your batteries / Des lignes horizontales, la rigueur du blanc, la fraîcheur du bois clair, les différents modules fermés et ouverts. Bienvenue dans une salle de bains idéale pour vivre et se ressourcer / Horizontale Linien, die Strenge der Farbe Weiß, die Frische des hellen Holzes, unterschiedliche geschlossene und offene Räume. Willkommen in einem Badezimmer zum Leben und Erholen / Líneas horizontales, el rigor del blanco, la frescura de la madera clara, elementos diferentes abiertos y cerrados. Bienvenidos a un baño para vivir y disfrutar





Mobile in finitura Dekorativo
3D Nodato Spaccato Biondo
con maniglia Delta.

Unit in Dekorativo 3D Nodato
Spaccato Biondo finish with
Delta handle.

Meuble en finition Dekorativo
3D Nodato Spaccato Biondo
avec poignée Delta.

Möbel im Finish Dekorativo
3D Nodato Spaccato Biondo
mit Griff Delta.

Mueble con acabado
Dekorativo 3D Nodato
Spaccato Biondo con
tirador Delta.





In queste immagini la composizione è presentata con maniglie Parentesi a disposizione contrapposta.

These images show the composition with Parentesi handles in a contrasting layout.

Ces images illustrent la composition avec les poignées Parentesi opposées.

In diesen Bildern ist eine Komposition mit den Griffen Parentesi mit entgegengesetzter Anordnung zu sehen.

En estas imágenes la composición se presenta con tiradores Parentesi de disposición contraria.



Caratteristiche tecniche / Technical features / Caractéristiques techniques /
Technische Merkmale / Rasgos técnicos



Dimensioni / Dimensions / Dimensions /
Größe / Dimensiones

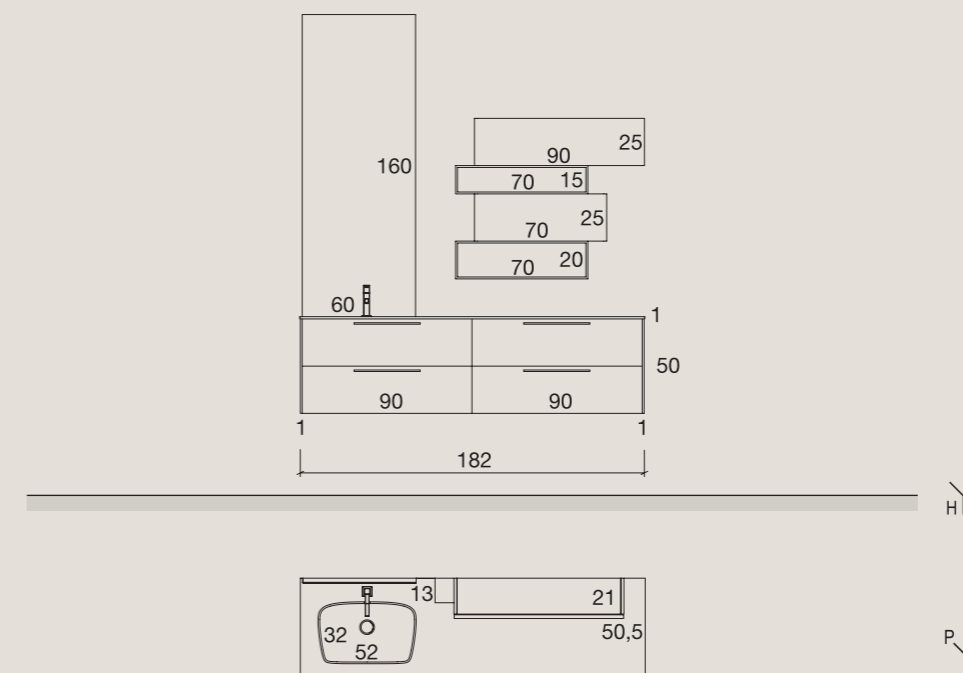

Finiture / Finishes / Finitions /
Oberflächen / Acabados

TOP CON VASCA INTEGRATA OLY



OCRITECH
BIANCO OPACO
COD. TD1

BASI



DEKORATIVO 3D
NODATO SPACCATO BIONDO
COD. 1NA

PENSILI



LACCATO BIANCO OPACO
COD. 20B

PENSILI A GIORNO



LACCATO NEBBIA OPACO
COD. 291

- 1 Top Sp. 1 cm con vasca integrata Oly L. 52 cm
- 2 Specchiera rettangolare L. 60 H. 160 cm
- 3 Maniglia Delta Nero Brunito
- 4 Pensili con apertura Push&Pull

- 1 Top Th. 1 cm with Oly recessed washbasin W. 52 cm
- 2 Rectangular wall mirror W. 60 H. 160 cm
- 3 Nero Brunito Delta handle
- 4 Wall units with Push&Pull opening system

- 1 Plan de toilette ép. 1 cm avec vasque intégrée Oly L. 52 cm
- 2 Miroir rectangulaire L. 60 H. 160 cm
- 3 Poignée Delta Nero Brunito
- 4 Éléments suspendus avec ouverture Push&Pull

- 1 Waschtischplatte Stärke: 1 cm mit eingelassenem Waschbecken Oly B. 52 cm
- 2 Rechteckiger Wandspiegel B. 60 H. 160 cm
- 3 Griff Delta Nero Brunito
- 4 Hängeschränke mit Push&Pull-Öffnung

- 1 Encimera Esp. 1 cm con lavabo integrado Oly A. 52 cm
- 2 Espejo rectangular A. 60 H. 160 cm
- 3 Tirador Delta Nero Brunito
- 4 Armarios con apertura Push&Pull

011 Uno stile minimale mai forzato. L'utilizzo di una calda finitura legno. Per unire rigore e tradizione in un ambiente elegante e raffinato / A minimal, effortless style. The use of a warm wood finish. To combine a crisp look with tradition in an elegant, refined setting / Un style minimaliste jamais exubérant. L'utilisation d'une chaleureuse finition bois. Pour marier rigueur et tradition en une pièce élégante et raffinée / Ein minimaler und niemals erzwungener Stil. Die Verwendung eines warmen Holzfinishes. Um Strenge und Tradition in einem eleganten und raffinierten Ambiente zu vereinen / Un estilo minimalista sin esfuerzo. El uso de un acabado cálido de madera. Para unir rigor y tradición en un ambiente elegante y refinado







Spazi perfettamente organizzati nel mobile in Dekorativo 3D Nodato Spaccato Tabacco. Consolle Snap in Mineralmarmo.

Perfectly organised space in the unit in Dekorativo 3D Nodato Spaccato Tabacco. Console Snap in Mineralmarble.

Des espaces parfaitement organisés ans le meuble en Dekorativo 3D Nodato Spaccato Tabacco. Plan-vasque Snap en Mineralbarbre.

Perfekt organisierte Räume im Möbel aus Dekorativo 3D Nodato Spaccato Tabacco. Konsolen Snap aus Mineralmarmo.

Espacios perfectamente organizados en el mueble en Dekorativo 3D Nodato Spaccato Tabacco. Consolle Snap en Mineralmarmo.





Gusto fashion nella
combinazione con vasca
personalizzata Quadra e top
in Deimos Text Visone.

An on-trend style in the
combination with the
customised Quadra basin and
top in Deimos Text Visone.

Goût très tendance pour
la combinaison avec vasque
Quadra personnalisée et plan
de toilettes en Deimos Text
Visone.

Modischer Geschmack in der
Kombination mit persönlich
gestaltetem Waschbecken
Quadra und Waschtischplatte
aus Deimos Text Visone.

Gusto fashion en la
combinación con lavabo
Quadra personalizado y
encimera en Deimos Text
Visone.

Caratteristiche tecniche / Technical features / Caractéristiques techniques /
Technische Merkmale / Rasgos técnicos

Dimensioni / Dimensions / Dimensions /
Größe / Dimensiones

Finiture / Finishes / Finitions /
Oberflächen / Acabados

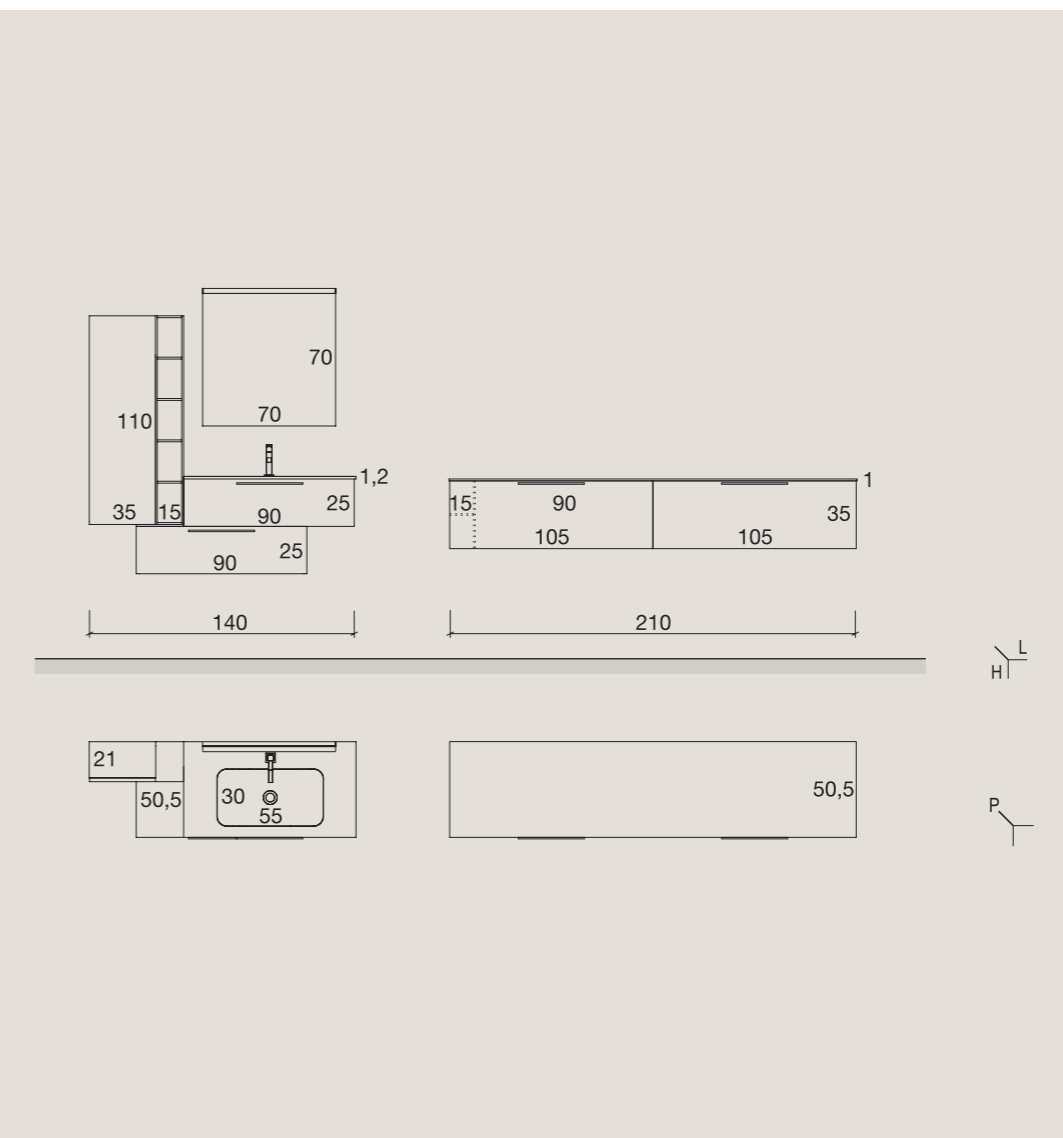

CONSOLLE SNAP



MINERALMARMO
BIANCO LUCIDO
COD. TM0

BASI / PENSILI



DEKORATIVO 3D
NODATO SPACCATO TABACCO
COD. 1NB

PENSILE A GIORNO

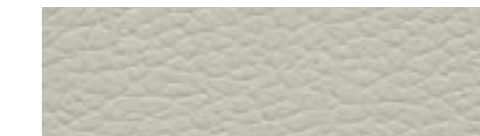

DEKORATIVO 3D
PRIMO FIORE EFFETTO PELLE CANAPA
COD. 1PC

BASI



LACCATO TITANIO LUCIDO
COD. 393

Variante

TOP CON VASCA INTEGRATA QUADRA



DEIMOS TEXT
VISONE
COD. TU5

- 1 Console Snap Sp. 1,2 cm con vasca L. 55 cm
- 2 Specchiera rettangolare L. 70 H. 70 cm
- 3 Lampada Led One (cod. LPNE070)
- 4 Maniglia Delta Nero Brunito
- 5 Pensili con apertura Push&Pull

- 1 Snap Console Th. 1.2 cm with washbasin W. 55 cm
- 2 Rectangular wall mirror W. 70 H. 70 cm
- 3 One LED light (code LPNE070)
- 4 Nero Brunito Delta handle
- 5 Wall units with Push&Pull opening system

- 1 Plan-vasque Snap Ép. 1,2 cm avec vasque L. 55 cm
- 2 Miroir rectangulaire L. 70 H. 70 cm
- 3 Lampe à Led One (code LPNE070)
- 4 Poignée Delta Nero Brunito
- 5 Éléments suspendus avec ouverture Push&Pull

- 1 Konsole Snap Stärke: 1,2 cm mit Waschbecken B. 55 cm
- 2 Rechteckiger Wandspiegel B. 70 H. 70 cm
- 3 LED-Lampe One (Cod. LPNE070)
- 4 Griff Delta Nero Brunito
- 5 Hängeschränke mit Push&Pull-Öffnung

- 1 Consolle Snap Esp. 1,2 cm con lavabo A. 55 cm
- 2 Espejo rectangular A. 70 H. 70 cm
- 3 Lámpara de Led One (cód. LPNE070)
- 4 Tirador Delta Nero Brunito
- 5 Colgantes con apertura Push&Pull

012 Un bagno minimal contemporaneo che coinvolge con giochi di pieni e vuoti, di forti contrasti materici, di singoli elementi indipendenti / A minimal, contemporary bathroom which draws you in with a play on solid and empty spaces, strong textural contrasts and strong individual elements / Une salle de bains minimaliste contemporaine qui enjôle avec des jeux de pleins et vides, de forts contrastes matériels, de forts éléments indépendants / Ein modernes, minimalistisches Badezimmer, das einen durch das Spiel zwischen Fülle und Leere, starker stofflicher Kontraste und starker unabhängiger Elemente mitreißt / Un baño minimalista contemporáneo que participa con juegos de espacios y coberturas, con contrastes fuertes de materiales, con elementos característicos independientes







LAVABO ICON 60

Preziose sensazioni naturali vengono suggerite dal piano top in HPL Unicolor Ardesia con due opzioni di elementi lavabo Tutto Fuori.

The top in HPL Unicolour Ardesia with two sit-on washbasins conjures up sophisticated natural sensations.

De précieuses sensations naturelles suggérées par le plan de toilette en UPL Unicolor Ardesia avec deux options d'éléments vasque à poser.

Die Waschtischplatte aus HPL Unicolor Ardesia mit zwei optionalen Aufsatzwaschtisch-Elementen vermittelt wertvolle natürliche Eindrücke.

Delicadas sensaciones naturales se sugieren con la mesada de la encimera en HPL Unicolor Ardesia con dos opciones de elementos lavabo externo.



LAVABO UNICA 55

Lime Ø/012
variante



LAVABO ICON 60R



LAVABO ICON CIRCLE

Colore e praticità nel piano
top Dekorativo 3D Nodato
Spaccato Biondo con
lavabo Tutto Fuori.

Colour and practicality
feature in the Dekorativo 3D
Nodato Spaccato Biondo
countertop with a sit-on
washbasin.

Couleur et praticité sur le
plan de toilette Dekorativo 3D
Nodato Spaccato Biondo avec
vasque à poser.

Farbe und Zweckmäßigkeit
der Waschtischplatte aus
Dekorativo 3D Nodato
Spaccato Biondo mit
Aufsatzwaschtisch.

Color y practicidad en la
mesada de la encimera
Dekorativo 3D Nodato
Spaccato Biondo con
lavabo externo.

Caratteristiche tecniche / Technical features / Caractéristiques techniques /
Technische Merkmale / Rasgos técnicos

Dimensioni / Dimensions / Dimensions /
Größe / Dimensiones

Finiture / Finishes / Finitions /
Oberflächen / Acabados

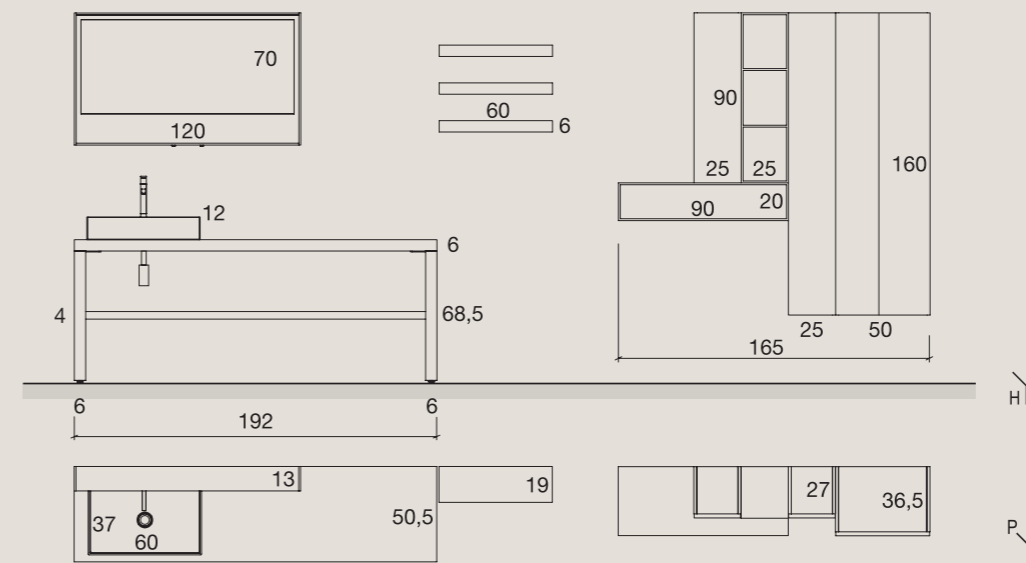

LAVABO TUTTO FUORI ICON 60



CERAMICA BIANCA

TOP SP. 6 CM



HPL UNICOLOR
ARDESIA
COD.TKF

**MENSOLE / MENSOLONE /
PENSILE A GIORNO / SPECCHIERA**



DEKORATIVO 3D
ROVERE SHERWOOD CASTANO
COD. 1S3

PENSILI / COLONNE

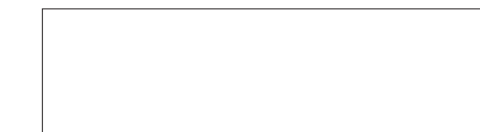

LACCATO BIANCO OPACO
COD. 20B

GAMBE METALLO



LACCATO
ANTRACITE METALLIZZATO OPACO
COD. 2M5

Variante

TOP SP. 6 CM



DEKORATIVO 3D
NODATO SPACCATO BIONDO
COD. 1NA

- 1 Lavabo Tutto Fuori Icon 60 (cod. LVEAECA60)
- 2 Top Sp. 6 cm
- 3 Specchiera Riquadro retroilluminata L. 120 H. 70 cm
- 4 Gambe in Metallo laccato H. 68,5 cm
- 5 Pensili e colonne con apertura Push&Pull

- 1 Icon 60 Sit-on Washbasin (code LVEAECA60)
- 2 Top Th. 6 cm
- 3 Riquadro wall mirror with backlighting W. 120 H. 70 cm
- 4 Legs in lacquered metal H. 68,5 cm
- 5 Wall units and tall units with Push&Pull opening system

- 1 Vasque à poser Icon 60 (code LVEAECA60)
- 2 Plan de toilette Ép. 6 cm
- 3 Miroir Riquadro rétroéclairé L. 120 H. 70 cm
- 4 Pieds en métal laqué H. 68,5 cm
- 5 Éléments suspendus et les colonnes avec ouverture Push&Pull

- 1 Aufsatzwaschtisch Icon 60 (Cod. LVEAECA60)
- 2 Waschtischplatte Stärke: 6 cm
- 3 Wandspiegel Riquadro von hinten beleuchtet B. 120 H. 70 cm
- 4 Beine aus lackiertem Metall H. 68,5 cm
- 5 Hängeschränke und Hockschränke mit Push&Pull-Öffnung

- 1 Lavabo externo Icon 60 (cód. LVEAECA60)
- 2 Encimera Esp. 6 cm
- 3 Espejo Riquadro retroiluminado A. 120 H. 70 cm
- 4 Patas de metal lacado H. 68,5 cm
- 5 Colgantes y las columnas con apertura Push&Pull

013 Ecomalta Argilla, laccato Perla opaco e riflessi metallizzati sono le finiture che si incontrano in questo bagno di ispirazione cinematografica / Ecomalta Argilla, matt Perla lacquer and metallic highlights are the finishes which are blended in this movie-set inspired bathroom / Ecomalta Argilla, laqué Perla mat et reflets métallisés sont les finitions qui se mélangent dans cette salle de bains à l'inspiration cinématographique / Ecomalta Argilla, lackiert Perla matt und Metallic-Reflexe sind die Finishes, die sich in diesem Badezimmer, das durch das Kino inspiriert wird, treffen / Ecomalta Argilla, lacado Perla opaco y reflejos metalizados son los acabados que se encuentran en este baño de inspiración cinematográfica







Ecomalta "Le Terre" Argilla per i frontali delle basi, top con vasca integrata Scivolo. Delicato Grigio Perla per le colonne con apertura Push&Pull.

Ecomalta "Le Terre" Argilla for the base unit front panels, top with Scivolo recessed washbasin. Delicate Grigio Perla for the tall units with Push&Pull opening system.

Ecomalta « Le Terre » Argilla pour les façades des éléments bas, plan de toilette avec vasque intégrée Scivolo. Délicatesse du Grigio Perla pour les colonnes avec ouverture Push&Pull.



Ecomalta „Le Terre“ Argilla für die Fronten der Unterschränke, Waschtischplatte mit eingelassenem Waschbecken Scivolo. Sanftes Grigio Perla für die Hochschränke mit Push&Pull-Öffnungssystem.

Ecomalta "Le Terre" Argilla para los frentes de las bases, encimera con lavabo integrado Scivolo. Delicado Grigio Perla para las columnas con apertura Push&Pull.



Texture ed effetti materici si accostano tra loro con originalità. A lato: particolare della finitura Reflex effetto Metallizzato. A destra: variante con maniglia Icon nella stessa finitura del frontale.

Textures and tactile effects are combined with originality. To the side: close-up of Reflex effetto Metallizzato finish. On the right: version with Icon handle in matching front panel finish.

Des textures et des effets matériels se marient avec originalité. Ci-contre : vue détaillée de la finition Reflex effetto Metallizzato. À droite : version poignée Icon, même finition que la façade.

Stoffliche Texturen und Effekte kombinieren sich mit ihren Fantasie miteinander. Auf der Seite: Detailansicht des Finishs Reflex effetto Metallizzato. Auf der rechten Seite: Variante mit Griff Icon mit demselben Finish wie die Front.

Textura y efectos matéricos se acompañan con armonía. Al lado: detalle del acabado Reflex efecto Metallizzato. A la derecha: variante con tirador con el mismo acabado del frente.



Caratteristiche tecniche / Technical features / Caractéristiques techniques /
Technische Merkmale / Rasgos técnicos

Dimensioni / Dimensions / Dimensions /
Größe / Dimensiones

Finiture / Finishes / Finitions /
Oberflächen / Acabados

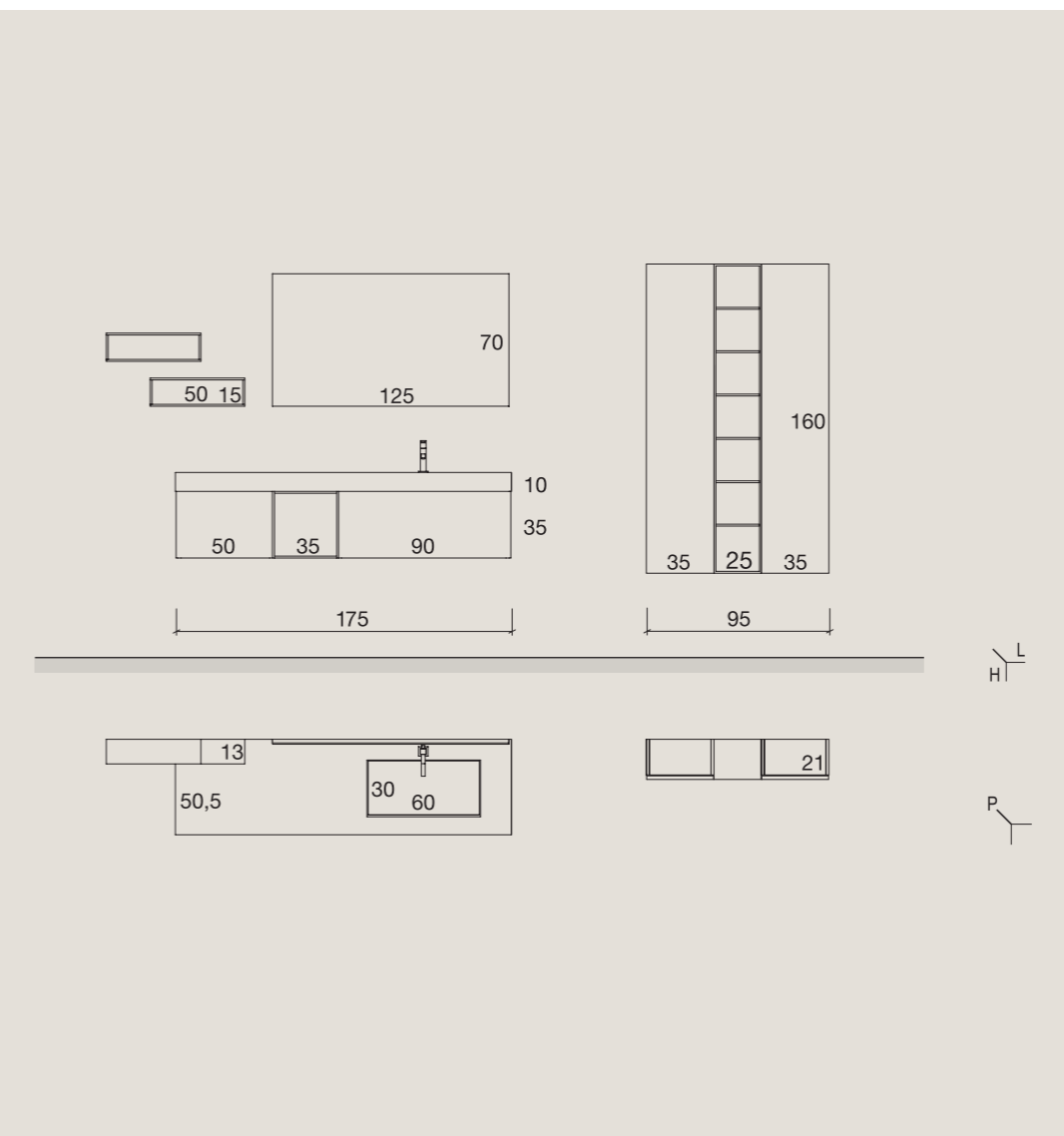

**TOP SCATOLATO SP. 10 CM CON VASCA
INTEGRATA SCIVOLO**

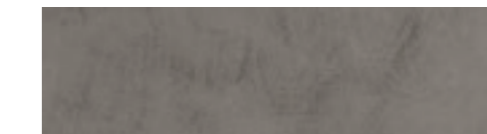

ECOMALTA "LE TERRE"
ARGILLA
COD. TCR

BASI

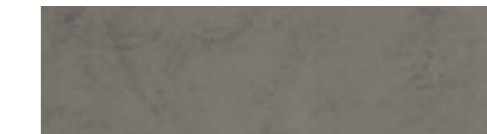

ECOMALTA "LE TERRE"
ARGILLA
COD. TCR

**PENSILI E BASE A GIORNO /
COLONNA A GIORNO**



DEKORATIVO 3D
REFLEX EFFETTO METALLIZZATO
COD. 1RE

COLONNE



LACCATO GRIGIO PERLA OPACO
COD. 233

1 Top Sp. 10 cm con vasca
integrata Scivolo L. 60 cm

2 Specchiera rettangolare
retroilluminata L. 125 H. 70 cm

3 Apertura Push&Pull

1 Top Th. 10 cm with Scivolo
recessed Washbasin W. 60 cm

2 Rectangular wall mirror with
backlighting W. 125 H. 70 cm

3 Push&Pull opening system

1 Plan de toilette Ép. 10 cm avec
vasque intégrée Scivolo L. 60 cm

2 Miroir rectangulaire
rétroéclairé L. 125 H. 70 cm

3 Ouverture Push&Pull

1 Waschtischplatte, Stärke: 10 cm
mit eingelassenem Waschbecken
Scivolo B. 60 cm

2 Rechteckiger Wandspiegel
von hinten beleuchtet
B. 125 H. 70 cm

3 Push&Pull-Öffnung

1 Encimera Esp. 10 cm con lavabo
integrado Scivolo A. 60 cm

2 Espejo rectangular
retroiluminado A. 125 H. 70 cm

3 Apertura Push&Pull

014 Forme e finiture che propongono in chiave attuale le avanguardie artistiche degli anni '70 si ritrovano in un bagno di personalità / Shapes and finishes with a modern take on the avant-garde artistic look of the 1970s create a bathroom full of character / Des formes et des finitions qui proposent dans une version actuelle les avant-garde artistiques des années 1970 se représentent dans une salle de bains à la forte personnalité / Formen und Finishes, welche die künstlerische Avantgarde der 70er Jahre modern interpretieren, finden sich in einem Badezimmer mit Charakter wieder / Formas y acabados que proponen con estilo actual las vanguardias artísticas de los años '70 se encuentran en un baño con personalidad







Sembra una riflessione
l'effetto creato dalle due
consolle Slim in ceramica con
vasca decentrata.

The effect created by the
two ceramic Slim consoles
with off-centre washbasin
looks like a mirror image.

Comme une réflexion,
l'effet créé par les deux
plans-vasques Slim en
céramique avec vasque
décentrée.

Er scheint eine Reflexion zu
sein, der Effekt, der durch
die beiden Konsolen Slim aus
Keramik mit dezentriertem
Waschbecken entsteht.

Parece una reflexión el efecto
creado por las dos consolle
Slim de cerámica con lavabo
descentralizado.



A sinistra: un'immagine della specchiera retroilluminata. In questa pagina: particolari della consolle Snap in Mineralmarmo e della maniglia Disko.

Left: an of the backlit wall mirror. On this page: close-ups of the Snap Console in Mineralmarble and the Disko handle.

À gauche : une illustration du miroir rétroéclairé. Sur cette page : vue détaillée du plan-vasque Snap en Mineralmarbre et de la poignée Disko.



Auf der linken Seite: ein Bild des von hinten beleuchteten Spiegels. Auf dieser Seite: Details der Konsole Snap aus Mineralmarmo und des Griffs Disko.

A la izquierda: una imagen del espejo retroiluminado. En esta página: piezas de la consolle Snap de Mineralmarmo y del tirador Disko.



Lime Ø/014
variante



Originale e pratico il piano con vasca Nettuno decentrata, entrambi in cristallo.

The glass top with off-centre glass Nettuno washbasin are both original and practical.

Original et pratique le plan avec vasque décentrée Nettuno, tous deux en verre.

Die Waschtischplatte mit dezentriertem Waschbecken Nettuno, beide aus Kristallglas, ist originell und praktisch.

Original y práctica la encimera con lavabo descentralizado Nettuno, ambos de cristal.



In questa variante il mobile è presentato con consolle Tak di alto spessore in ceramica.

In this variation, the unit is shown with a chunky Tak console in ceramic.

Dans cette version le meuble se présente avec plan-vasque Tak très épais en céramique.

In dieser Variante wird das Möbel mit Konsolen Tak gezeigt mit einer großer Stärke aus Keramik.

En esta variante el mueble se presenta con consolle Tak de alto espesor de cerámica.



Caratteristiche tecniche / Technical features / Caractéristiques techniques /
Technische Merkmale / Rasgos técnicos

Dimensioni / Dimensions / Dimensions /
Größe / Dimensiones

Finiture / Finishes / Finitions /
Oberflächen / Acabados

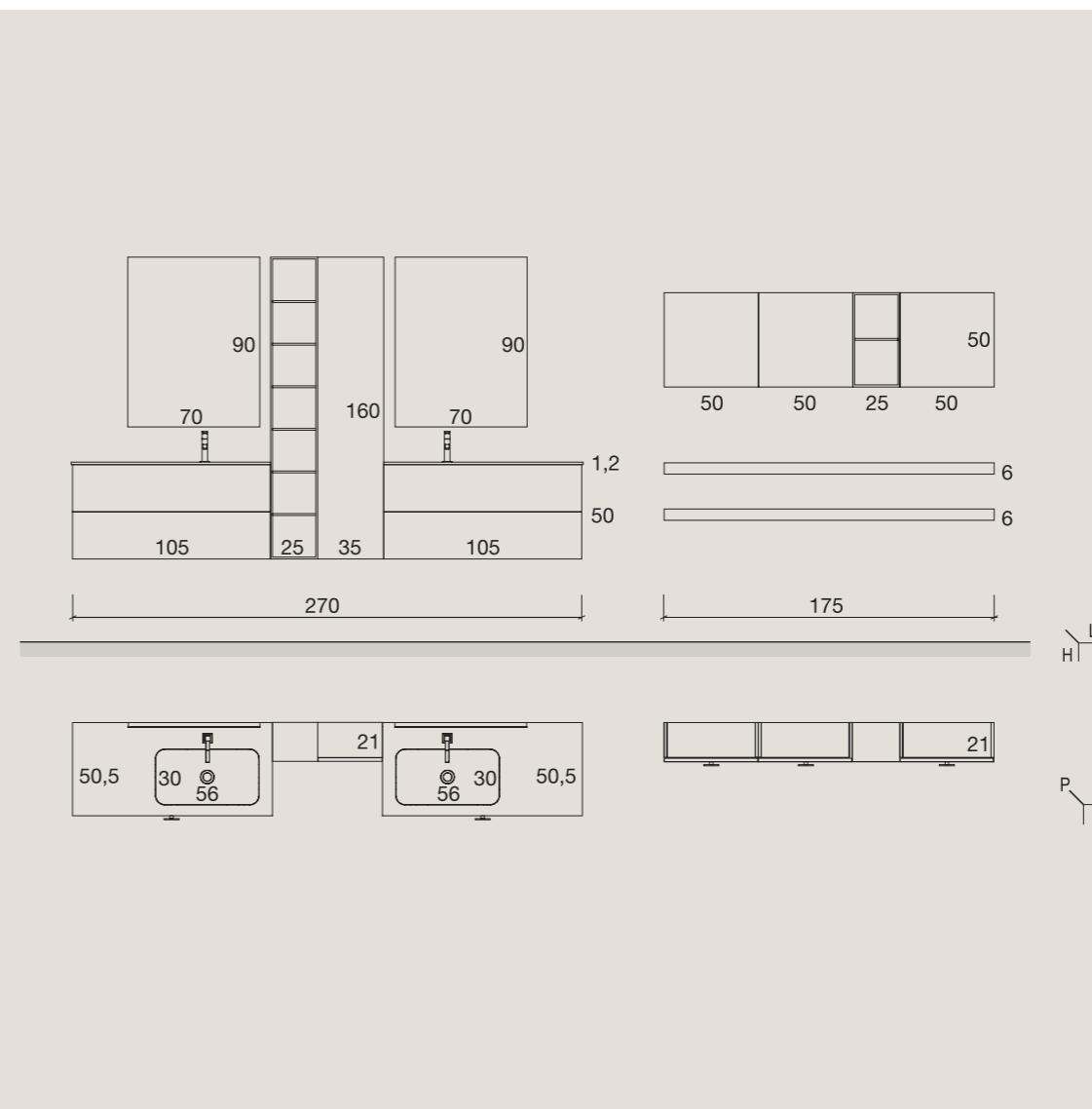

CONSOLE CERAMICA SLIM



CERAMICA BIANCA

BASI / PENSILI / COLONNA



LACCATO BIANCO LUCIDO
COD. 30B

COLONNA A GIORNO / MENSOLE



DEKORATIVO 3D
EUCALIPTO SABLÈ GRIGIO
COD. 1SA

Variante

CONSOLE SNAP



MINERALMARMO BIANCO LUCIDO
COD. TM0

TOP CON VASCA INTEGRATA NETTUNO



CRISTALLO BIANCO LUCIDO
COD. C0B

CONSOLE TAK



CERAMICA BIANCA

- 1 Consolle Ceramica Slim con vasca decentrata
- 2 Specchiera rettangolare retroilluminata a Led L. 70 H. 90 cm
- 3 Apertura Push&Pull
- 4 Colonna con apertura Push&Pull

- 1 Slim ceramic console with off-centre washbasin
- 2 Rectangular wall mirror with LED backlighting W. 70 H. 90 cm
- 3 Push&Pull opening system
- 4 Tall unit with Push&Pull opening system

- 1 Plan-vasque céramique Slim avec vasque décentrée
- 2 Miroir rectangulaire Rétroéclairé à Led L. 70 H. 90 cm
- 3 Ouverture Push&Pull
- 4 Colonne avec ouverture Push&Pull

- 1 Konsolen Keramik Slim mit dezentriertem Waschbecken
- 2 Rechteckiger, von hinten beleuchteter Wandspiegel mit LED B. 70 H. 90 cm
- 3 Push&Pull-Öffnung
- 4 Hochschrank mit Push&Pull-Öffnung

- 1 Consolle Ceramica Slim con lavabo descentrado
- 2 Espejo rectangular retroiluminado con Led A. 70 H. 90 cm
- 3 Apertura Push&Pull
- 4 Columna con apertura Push&Pull

015 Quando il design trasforma un'esigenza in un elemento di forte carattere nasce un ambiente dalla personalità unica / When the design transforms a requirement into a signature element, the result is a truly unique space / Le design transforme une exigence en un élément au caractère fort et donne naissance à une pièce à la personnalité unique / Wenn das Design einen Anspruch in ein charakteristisches Element verwandelt entsteht ein Ambiente mit einer einzigartigen Persönlichkeit / Cuando el diseño transforma una exigencia en un elemento de fuerte carácter nace un ambiente de personalidad única







Inusuale e piacevole questa composizione a profondità ridotta con vasca sporgente.

An unusual, but attractive, slimline composition with protruding basin.

Inusuelle et plaisante, cette composition peu profonde avec vasque en saillie.

Ungewöhnlich und angenehm ist diese Zusammenstellung mit reduzierter Tiefe und einem hervorragenden Waschbecken.

Inusual y agradable esta composición de reducida profundidad con lavabo saliente.



Sopra il piano con vasca Oly sporgente, la grande specchiera rettangolare dotata di lampada a led.

Above the protruding Oly basin, the large rectangular wall mirror, fitted with LED lights.

Le grand miroir rectangulaire doté de lampe à led trouve sa place au-dessus du plan avec vasque Oly en saillie.

Oben die Waschtischplatte mit hervorragendem Waschbecken Oly, der große rechteckige Wandspiegel mit LED-Lampe.

Sobre la encimera con lavabo Oly saliente, el gran espejo rectangular dotado de lámpara led.



Lime Ø/015
variante

In questa variante il top prevede la vasca integrata Scivolo. Ricca e completa la dotazione interna di contenitori.

In this variation, the top has a Scivolo recessed washbasin. The internal storage space is comprehensive and complete.

Dans cette version, le plan de toilette prévoit la vasque intégrée Scivolo. Riche et exhaustif, l'aménagement de rangement interne.

In dieser Variante hat die Waschtischplatte ein eingelassenes Waschbecken Scivolo. Die Innenausstattung der Elemente ist üppig und umfassend.

En esta variante la encimera prevé el lavabo integrado Scivolo. Abundante y completa la dotación interna de los recipientes.



Caratteristiche tecniche / Technical features / Caractéristiques techniques /
Technische Merkmale / Rasgos técnicos



Dimensioni / Dimensions / Dimensions /
Größe / Dimensiones

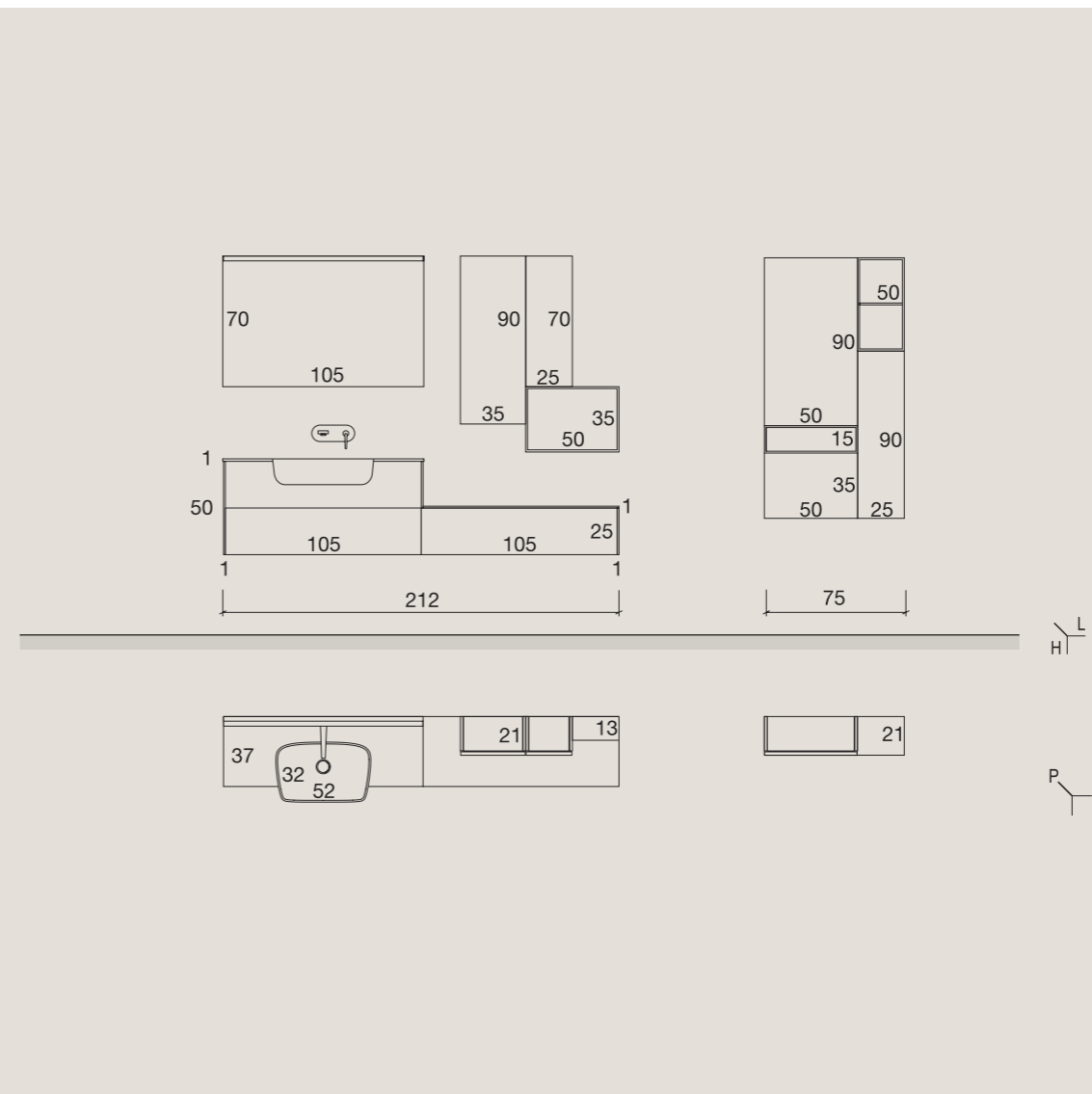

Finiture / Finishes / Finitions /
Oberflächen / Acabados

**TOP CON VASCA INTEGRATA SEMINCASSO
OLY**

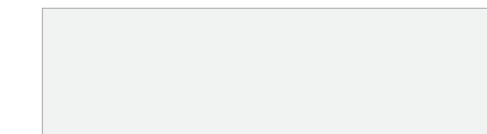

OCRITECH BIANCO OPACO
COD. TD1

BASI



DEKORATIVO 3D
EUCALIPTO SABLÈ CANALETTO
COD. 1SB

PENSILI

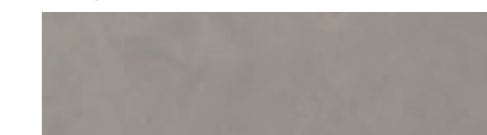

DEKORATIVO 3D
CEMENTO CRETA
COD. 1A3

PENSILE A GIORNO



LACCATO BIANCO OPACO
COD. 20B

Variante

TOP CON VASCA INTEGRATA SCIVOLO



TECNORIL
BIANCO OPACO
COD. TT0

- 1 Top Sp. 1 cm con vasca integrata Oly semincasso L. 52 cm
- 2 Specchiera rettangolare L. 105 H. 70 cm
- 3 Lampada Led One (cod. LPNE0A5)
- 4 Apertura Push&Pull

- 1 Top Th.1 cm with semi-recessed Oly basin W. 52 cm
- 2 Rectangular wall mirror W. 105 H. 70 cm
- 3 One LED light (code LPNE0A5)
- 4 Push&Pull opening system

- 1 Plan de toilette Ép. 1 cm avec vasque intégrée Oly Semi-encasté L. 52 cm
- 2 Miroir rectangulaire L. 105 H. 70 cm
- 3 Lampe à Led One (code LPNE0A5)
- 4 Ouverture Push&Pull

- 1 Waschtischplatte Stärke: 1 cm mit Halbeinbau-Waschbecken Oly B. 52 cm
- 2 Rechteckiger Wandspiegel B. 105 H. 70 cm
- 3 LED-Lampe One (Cod. LLPNE0A5)
- 4 Push&Pull-Öffnung

- 1 Encimera Esp. 1 cm con lavabo integrado Oly semi empotrado A. 52 cm
- 2 Espejo rectangular A. 105 H. 70 cm
- 3 Lámpara Led One (cód. LPNE0A5)
- 4 Apertura Push&Pull

016 Nel mobile su più livelli la maniglia high tech incontra il calore dell'Eucalipto Sablè Termocotto e il top HPL Unicolor con vasca integrata Malta Grigia / In the multi-level unit, the high-tech handle is combined with the warmth of Eucalipto Sablè Termocotto, and the top HPL Unicolor with recessed washbasin in Malta Grigia / Dans le meuble à plusieurs étages, la poignée high-tech rencontre la chaleur de l'Eucalipto Sablè Termocotto et le plan de toilette HPL Unicolor avec vasque intégrée Malta Grigia / Am Möbelstück trifft der Hightech-Griff die Wärme des Eucalipto Sablè Termocotto und die Waschtischplatte HPL Unicolor mit eingelassenem Waschbecken Malta Grigia / En el mueble con varios niveles el tirador high tech encuentra el calor del Eucalipto Sablè Termocotto y la encimera HPL Unicolor con lavabo integrado Malta Grigia







La qualità di questo mobile è evidente nel raffinato dettaglio della texture accostato al rigore della maniglia Lateral.

The quality of this unit is evident in the sophisticated detail of the texture combined with the sober style of the Lateral handle.



La qualité de ce meuble est incontestable dans le détail raffiné de la texture mariée à la rigueur de la poignée Lateral.

Die Qualität dieses Möbelstücks ist offensichtlich im raffinierten Detail der Textur, kombiniert mit der Strenge des Griffs Lateral.

La calidad de este mueble es evidente en el refinado detalle de la textura junto con la precisión del tirador Lateral.

Caratteristiche tecniche / Technical features / Caractéristiques techniques /
Technische Merkmale / Rasgos técnicos



Dimensioni / Dimensions / Dimensions /
Größe / Dimensiones

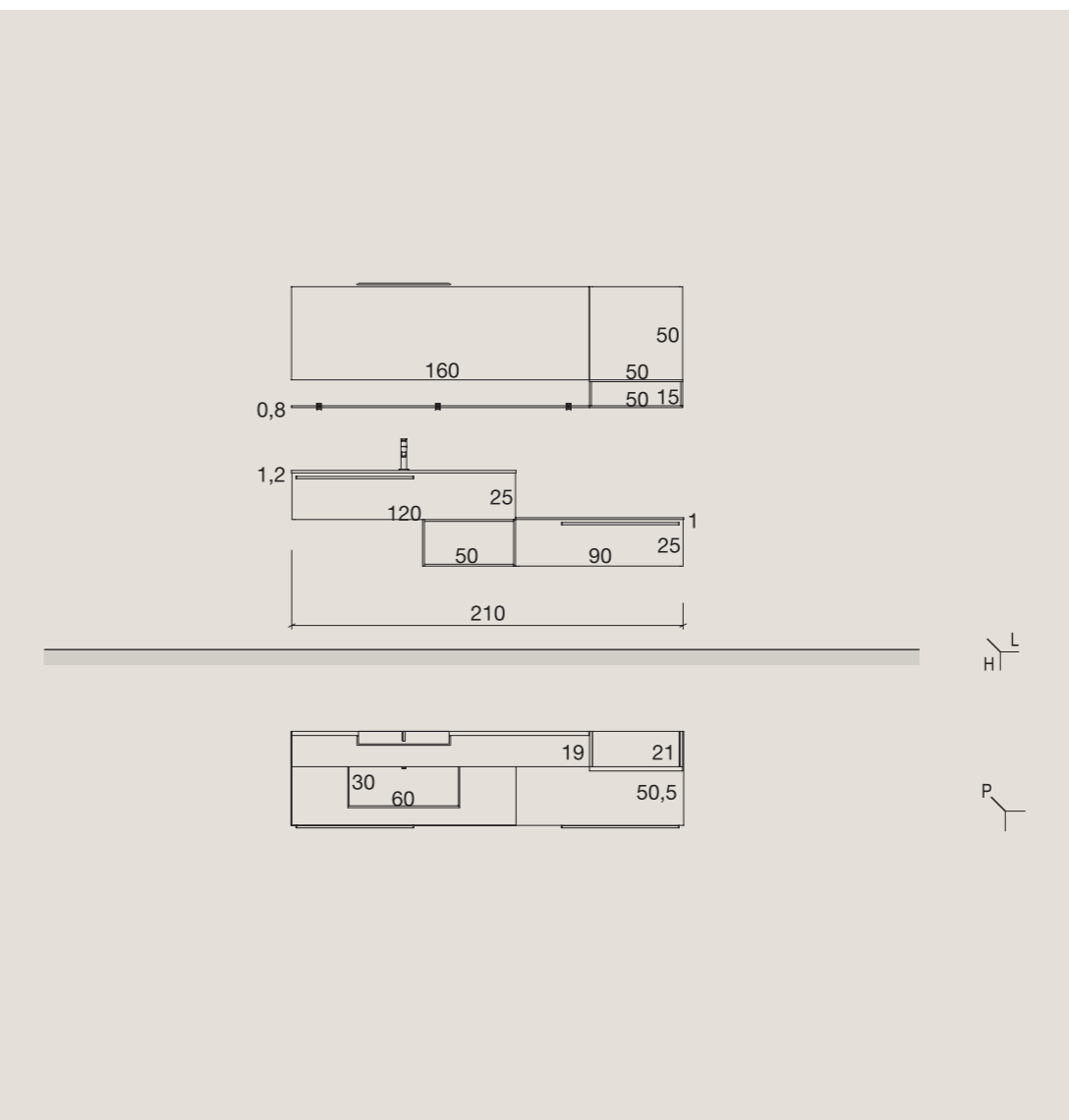

Finiture / Finishes / Finitions /
Oberflächen / Acabados

TOP CON VASCA INTEGRATA SCIVOLO



HPL UNICOLOR
MALTA GRIGIA
COD. TKE

BASI



DEKORATIVO 3D
EUCALIPTO SABLÈ TERMOCOTTO
COD. 1SC

BASE A GIORNO / PENSILE A GIORNO

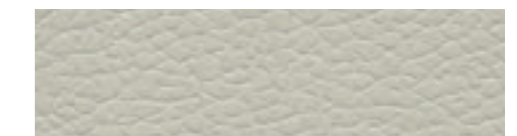

DEKORATIVO 3D
PRIMO FIORE EFFETTO PELLE CANAPA
COD. 1PC

1 Top Sp. 1,2 cm con vasca
integrata Scivolo L. 60 cm

2 Specchiera rettangolare
L. 160 H. 50 cm

3 Lampada Led Thin
(cod. LPTH050)

4 Maniglia Lateral Brill su basi
(Pensile Push&Pull)

1 Top Th. 1.2 cm with Scivolo
recessed basin W. 60 cm

2 Rectangular wall mirror with
backlighting W. 125 H. 50 cm

3 Thin LED light (code LPTH050)

4 Lateral Brill handle on base units
(Push&Pull wall unit)

1 Plan de toilette Ép. 1,2 cm avec
vasque intégrée Scivolo L. 60 cm

2 Miroir rectangulaire L. 160 H. 50 cm

3 Lampe à Led Thin (code LPTH050)

4 Poignée Lateral Brill sur
éléments bas (Élément
suspendu Push&Pull)

1 Waschtischplatte Stärke: 1,2 cm
mit eingelassenem Waschbecken
Scivolo B. 60 cm

2 Rechteckiger Wandspiegel
B. 160 H. 50 cm

3 LED-Lampe Thin (Cod. LPTH050)

4 Griff Lateral Brill an
Unterschrank (Push&Pull-
Hängeschränk)

1 Encimera Esp. 1,2 cm con
lavabo integrado Scivolo A. 60 cm

2 Espejo rectangular A. 160 H. 50 cm

3 Lámpara de Led Thin
(cód. LPTH050)

4 Tirador Lateral Brill sobre
muebles (Armario apertura
Push&Pull)

017 Giochi di spessori, volumi e finiture. Elementi a giorno. Disallineamenti. Le combinazioni del sistema Lime Ø non hanno limiti / Juxtaposition of thicknesses, volumes and finishes. Open elements. Misalignments There are no limits to the combinations of the Lime Ø system / Jeux d'épaisseur, volumes et finitions. Éléments ouverts. Désalignements. Les combinaisons du système Lime Ø n'ont aucune limite / Spiele aus Stärken, Räumen und Finishes. Offene Elemente. Fehlende Ausrichtungen. Die Kombinationen des Systems Lime Ø haben keine Grenzen / Juego de espesores, volúmenes y acabados. Elementos abiertos. Desalineados. Las combinaciones del sistema Lime Ø no tienen límites







La maniglia cromata stacca con un elemento di puro design sulle sensazioni naturali del mobile sospeso.

The chrome-plated handle is a stand-out, pure design element on the natural effect of the wall-mounted unit.

La poignée chromée se distingue avec un élément au design pur sur les sensations naturelles du meuble suspendu.

Der verchromte Griff hebt sich mit einem puren Design-Element von den natürlichen Eindrücken des hängenden Möbelstücks ab.

El tirador cromado resalta con un elemento de puro diseño sobre las sensaciones naturales del mueble colgante.



La vasca Tivi esclusiva Azzurra è integrata nell'elemento top in un materiale di tendenza. A destra: colonne pensili a doppia profondità.

The exclusive Tivi Azzurra washbasin is recessed in the top in an on-trend material. Right: double depth tall wall units.

La vasque Tivi exclusive Azzurra est intégrée au plan dans un matériau très tendance. À droite: colonnes suspendues à deux profondeurs.

Das exklusive Waschbecken Tivi Azzurra ist in das Waschtischplatten-Element in einem trendigen Material eingelassen. Auf der rechten Seite: Hängehochschränke mit doppelter Tiefe.

El lavabo Tivi exclusiva Azzurra está integrado en el elemento encimera de un material de moda. A la derecha: columnas armarios de doble profundidad.





Una variante compositiva dello stesso ambiente che utilizza un piano in Ecomalta "Le Terre" Argilla con vasca integrata Scivolo.

A composition variation of the same room using a top in Ecomalta "Le Terre" Argilla with Scivolo recessed washbasin.

Une version composée de la même pièce avec plan en Ecomalta « Le Terre » Argilla avec vasque intégrée Scivolo.

Eine Kombinationsmöglichkeit des gleichen Ambiente, die eine Waschtischplatte aus Ecomalta „Le Terre“ Argilla verwendet mit eingelassenem Waschbecken Scivolo.

Una variante compositiva del mismo ambiente que utiliza una encimera de Ecomalta "Le Terre" Argilla con lavabo integrado Scivolo.

Caratteristiche tecniche / Technical features / Caractéristiques techniques /
Technische Merkmale / Rasgos técnicos

Dimensioni / Dimensions / Dimensions /
Größe / Dimensiones

Finiture / Finishes / Finitions /
Oberflächen / Acabados

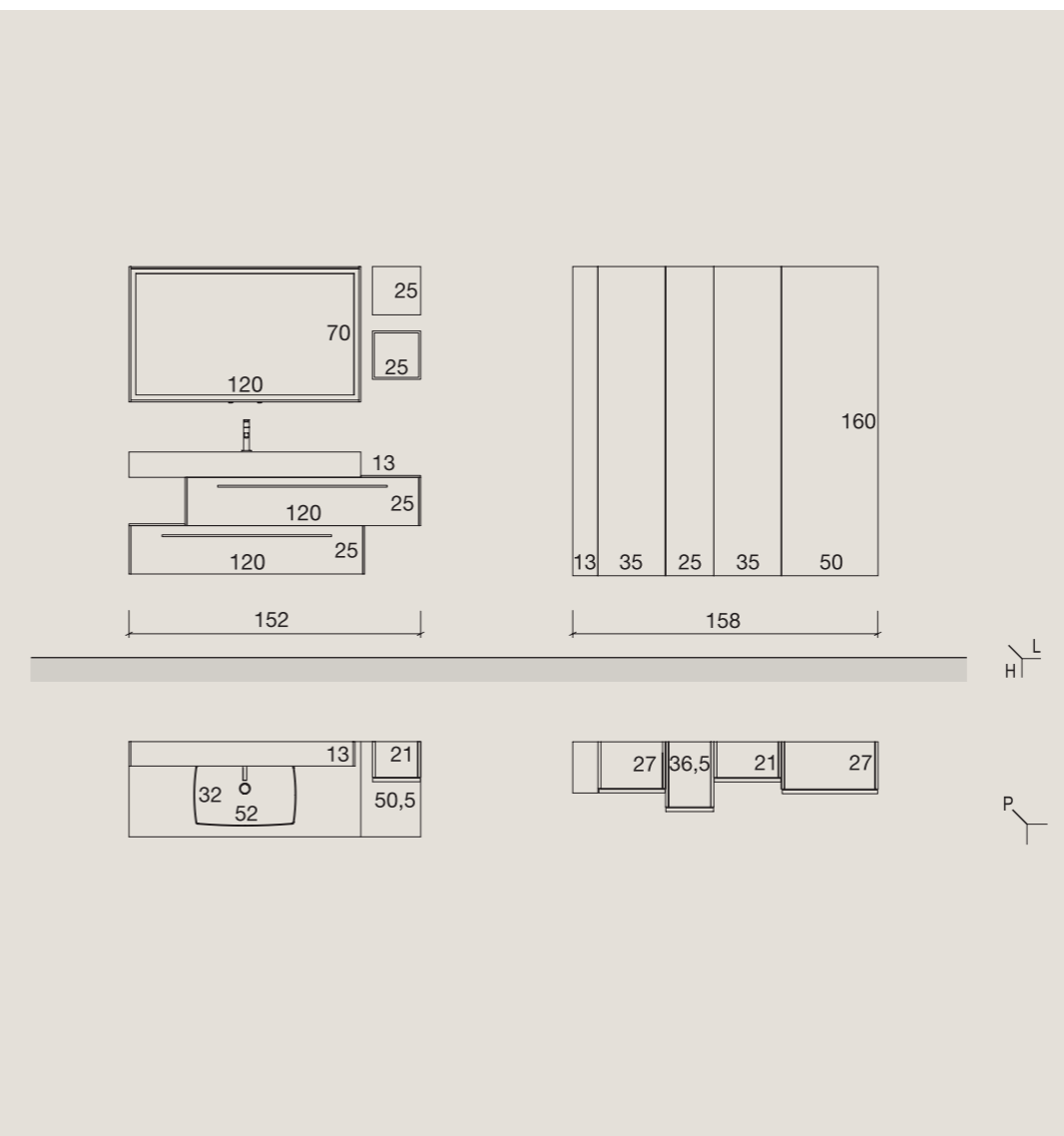

TOP CON VASCA INTEGRATA TIVI



MINERALMARMO CALCE
GRIGIO
COD. TAD

BASI / PENSILI



DEKORATIVO 3D
ROVERE DOGATO GRIGIO
COD. 1SA

PENSILI A GIORNO



LACCATO BLU ARTICO OPACO
COD. 237

COLONNE



DEKORATIVO 3D
CEMENTO CENERE
COD. 1A3

Variante

TOP CON VASCA INTEGRATA SCIVOLO

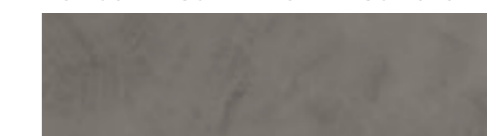

ECOMALTA "LE TERRE"
ARGILLA
COD. TCR

- 1 Top Sp. 13 cm con vasca integrata Tivi L. 52 cm
- 2 Specchiera Perimetro retroilluminata a Led L. 120 H. 70 cm
- 3 Maniglia Brio Cromo
- 4 Pensili con apertura Push&Pull

- 1 Top Th. 13 cm with Tivi recessed basin W. 52 cm
- 2 Perimetro wall mirror with LED backlighting W. 120 H. 70 cm
- 3 Chrome-plated Brio handle
- 4 Wall units with Push&Pull opening system

- 1 Plan de toilette Ép. 13 cm avec vasque intégrée Tivi L. 52 cm
- 2 Miroir Perimetro rétroéclairé à Led L. 120 H. 70 cm
- 3 Poignée Brio chromée
- 4 Éléments suspendus avec ouverture Push&Pull

- 1 Waschtischplatte Stärke: 13 cm mit eingelassenem Waschbecken Tivi B. 52 cm
- 2 Wandspiegel Perimetro mit LED von hinten beleuchtet B. 120 H. 70 cm
- 3 Griff Brio Cromo
- 4 Hängeschränke mit Push&Pull-Öffnung

- 1 Encimera Esp. 13 cm con lavabo integrado Tivi A. 52 cm
- 2 Espejo rectangular retroiluminado con Led A. 120 H. 70 cm
- 3 Tirador Brio Cromo
- 4 Armarios con apertura Push&Pull

018 Curve sensuali disegnano nello spazio un'estetica armoniosa e accogliente per un ambiente bagno originale e seducente / Sensual curves create a graceful, welcoming look for an original, alluring bathroom / Des courbes sensuelles dessinent dans l'espace une esthétique harmonieuse et accueillante pour une salle de bains originale et séduisante / Sinnliche Kurven zeichnen eine harmonische und einladende Ästhetik für ein originelles und verführerisches Badezimmer / Sensuales curvas diseñan en el espacio una estética armoniosa y acogedora para un ambiente del baño original y seductor







La forma della maniglia Brio segue il disegno curvo frontale laccato Bianco opaco.

The shape of the Brio handle follows the curve of the door in a matt Bianco lacquer finish.

La forme de la poignée Brio suit le dessin arrondi de la porte laquée Bianco mat.

Die Form des Griffs Brio folgt dem kurvigen Design der lackierten Tür in Bianco matt.



La forma del tirador Brio continua el diseño curvo de la puerta lacada Bianco opaco.



Vous n'avez pratiquement aucune limite pour personnaliser votre salle de bains avec Lime Ø.

Die Möglichkeiten für die persönliche Gestaltung Ihres Badezimmers sind mit Lime Ø unbegrenzt.

Prácticamente sin límites son las posibilidades de personalizar vuestro baño con Lime Ø.

Praticamente senza limiti sono le possibilità di personalizzare il vostro bagno con Lime Ø.

There are virtually no limits to the possibilities of customising your bathroom with Lime Ø.



Caratteristiche tecniche / Technical features / Caractéristiques techniques /
Technische Merkmale / Rasgos técnicos

Dimensioni / Dimensions / Dimensions /
Größe / Dimensiones

Finiture / Finishes / Finitions /
Oberflächen / Acabados

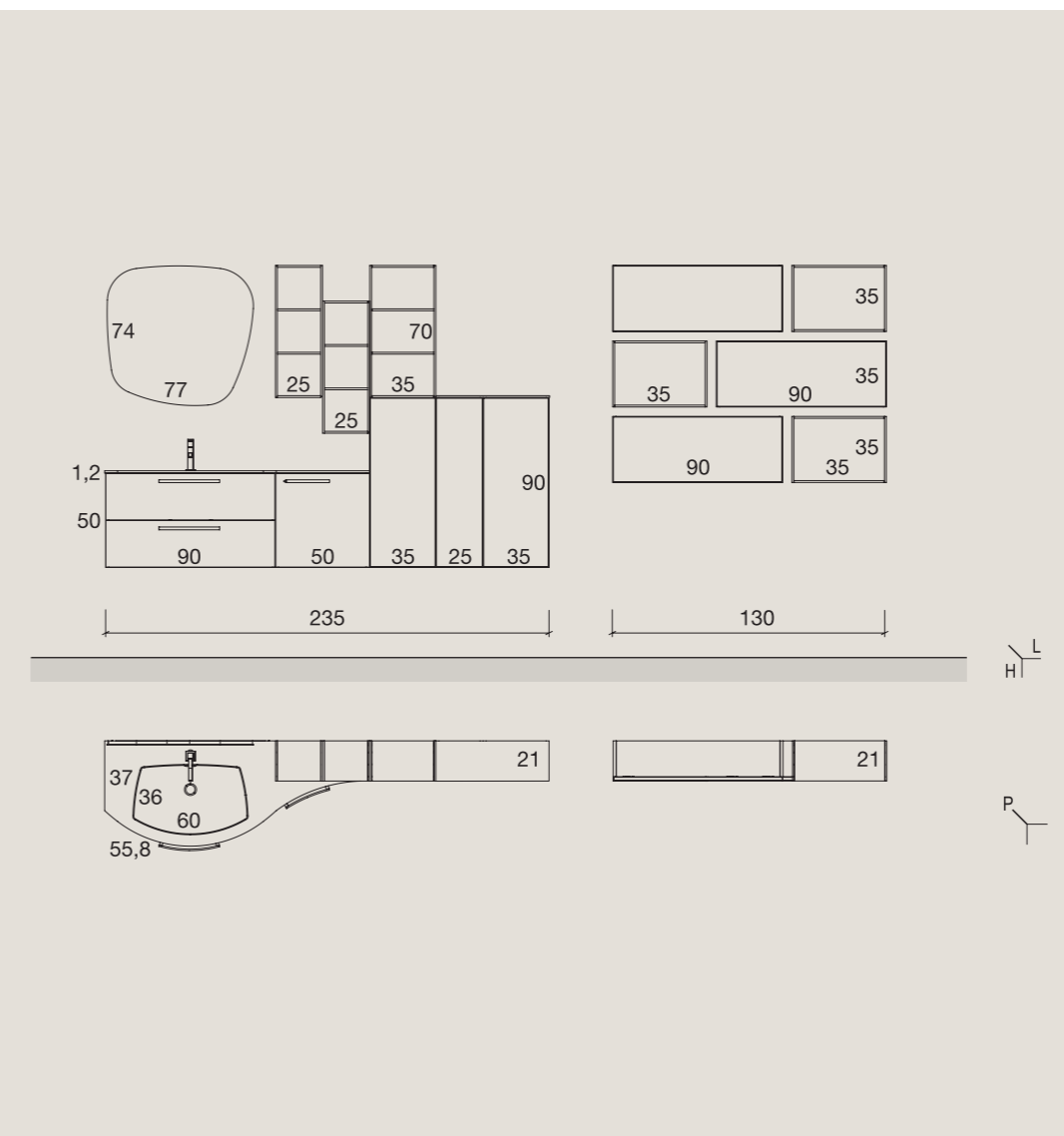

TOP CON VASCA INTEGRATA TIVI



MINERALMARMO CALCE
TORTORA
COD. TAC

BASI / PENSILI

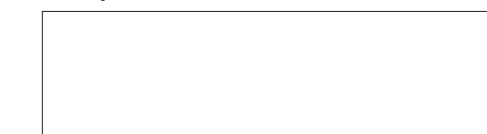

LACCATO BIANCO OPACO
COD. 20B

PENSILI A GIORNO

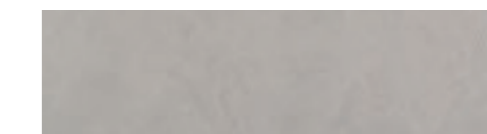

DEKORATIVO 3D
CEMENTO TORTORA
COD. 1A2

- 1 Top Sp. 1,2 cm con vasca integrata Tivi L. 60 cm
- 2 Specchiera Sasso Quadro retroilluminata L. 77 H. 74 cm
- 3 Maniglia Brio Cromo
- 4 Pensili con apertura Push&Pull

- 1 Top Th. 1.2 cm with Tivi recessed washbasin W. 60 cm
- 2 Sasso Quadro wall mirror with backlighting W. 77 H. 74 cm
- 3 Chrome-plated Brio handle
- 4 Wall units with Push&Pull opening system

- 1 Plan de toilette Ép. 1,2 cm avec vasque intégrée Tivi L. 60 cm
- 2 Miroir Sasso Quadro rétroéclairé à Led L. 77 H. 74 cm
- 3 Poignée Brio chromée
- 4 Éléments suspendus avec ouverture Push&Pull

- 1 Waschtischplatte Stärke: 1,2 cm mit eingelassenem Waschbecken Tivi B. 60 cm
- 2 Wandspiegel Sasso Quadro von hinten beleuchtet B. 77 H. 74 cm
- 3 Griff Brio Cromo
- 4 Hängeschränke Push&Pull-Öffnung

- 1 Encimera Esp. 1,2 cm con lavabo integrado Tivi A. 60 cm
- 2 Espejo Sasso Quadro retroiluminado A. 77 H. 74 cm
- 3 Tirador Brio Cromo
- 4 Armarios con apertura Push&Pull

019 Un ambiente appagante per ogni senso, equilibri di volumi si accostano ad abbinamenti tra finiture contrastanti, elementi e colori dialogano per creare un bagno accogliente e prezioso / A space that gratifies all senses, where balanced units are combined with contrasting finishes, elements and colours to create a welcoming, sophisticated bathroom / Une pièce qui satisfait tous les sens, les équilibres de volumes se mélangent aux assortiments entre les finitions contrastantes, les éléments et les couleurs dialoguent pour créer une salle de bains accueillante et luxueuse / Ein Ambiente, das alle Sinne befriedigt, Gleichgewichte aus Räumen neben Kombinationen aus kontrastreichen Finishes, Elementen und Farben kommunizieren, um ein einladendes und kostbares Badezimmer zu schaffen / Un ambiente gratificante para cada uno de los sentidos, equilibrios de volúmenes se combinan con acabados contrastantes, elementos y colores dialogan para crear un baño acogedor y preciado







Giochi di volumi con profondità di poco differenti. Finitura legno unita a Dekorativo 3D in Cemento Creta.

A play on volumes with slightly different depths. Wood finish combined with Dekorativo 3D in Cemento Creta.

Des jeux de volumes avec des profondeurs légèrement différentes. Finition bois Unifié à Dekorativo 3D en Cemento Creta.

Spiele aus Rauminhalten etwas unterschiedlicher geringer Tiefe. Holzfinish zusammen mit Dekorativo 3D aus Cemento Creta.

Juegos de volúmenes con profundidades levemente diferentes. Acabado de madera junto a Dekorativo 3D de Cemento Creta.





Piano top in Mineralmarmo Calce Bianco con vasca integrata Tivi esclusiva Azzurra.

Counter top in Mineralmarble Calce Bianco with Tivi exclusive Azzurra recessed basin.

Plan en Mineralmarbre Calce Bianco avec vasque Intégrée Tivi exclusive Azzurra.

Waschtischplatte aus Mineralmarmo Calce Bianco mit eingelassenem exklusivem Waschbecken Tivi Azzurra.

Mesada de la encimera en Mineralmarmo Calce Bianco con lavabo integrado Tivi exclusivo Azzurra.





- 1 Top Sp. 1 cm con vasca integrata Cover L. 50 cm
- 2 Specchiera Riquadro retroilluminata con mensole L. 140 H. 70 cm
- 3 Maniglia Lateral laccata in tinta

- 1 Top Th. 1 cm with integrated skin Cover W. 50 cm
- 2 Riquadro wall mirror with backlighting and shelves W. 140 H. 70 cm
- 3 Lateral handle in matching lacquer finish

- 1 Plan de toilette Ép. 1 cm avec vasque intégrée Cover L. 50 cm
- 2 Miroir rectangulaire Riquadro rétroéclairé à Led L. 140 H. 70 cm
- 3 Poignée Lateral laquée de la même couleur

- 1 Waschtischplatte Stärke: 1 cm mit eingelassenem Waschbeck Cover B. 50 cm
- 2 Wandspiegel Riquadro von hinten beleuchtet mit Ablagen B. 140 H. 70 cm
- 3 Griff Lateral lackiert einfarbig

- 1 Encimera Esp. 1 cm con lavabo integrado Cover A. 50 cm
- 2 Espejo Riquadro retroiluminado con estantes A. 140 H. 70 cm
- 3 Tirador Lateral lacado del color del mueble

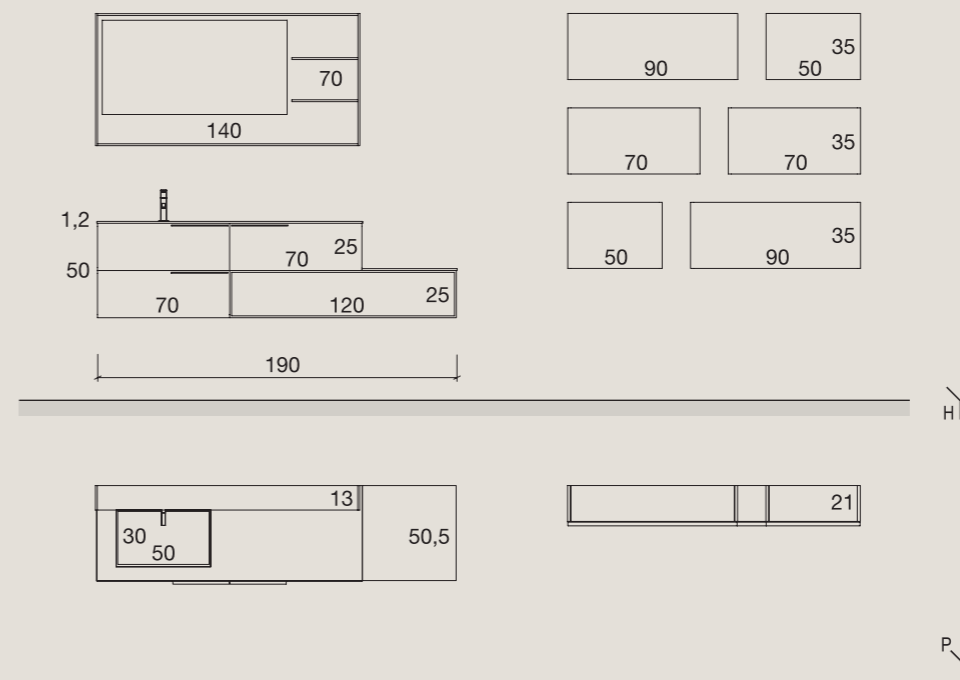

TOP CON VASCA INTEGRATA COVER



GRES PORCELLANATO BIANCO
STATUARIO LUCIDATO
COD. TQC

BASI / PENSILI



DEKORATIVO 3D
EUCALIPTO SABLÈ GRIGIO
COD.1SA

BASE GIORNO / PENSILI / SPECCHIERA



DEKORATIVO 3D CEMENTO CRETA
COD.1A3

Variante

TOP CON VASCA INTEGRATA TIVI

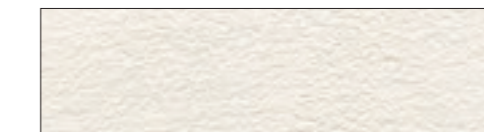

MINERALMARMO CALCE BIANCO
COD. TAA

BASE GIORNO / SPECCHIERA



DEKORATIVO 3D CEMENTO OLTREMARE
COD. 1A4

SCHIENALE SPECCHIERA



DEKORATIVO 3D
EUCALIPTO SABLÈ GRIGIO
COD. 1SA

DETTAGLI ESTETICI, SOLUZIONI FUNZIONALI, ACCORGIMENTI TECNICI ED ERGONOMICI CHE AGGIUNGONO VALORE E PRESTIGIO AL VOSTRO BAGNO AZZURRA

Aesthetic details, functional solutions, technical and ergonomic expedients which add value and prestige to your Azzurra bathroom

Des détails esthétiques, des solutions fonctionnelles, des éléments techniques et ergonomiques qui valorisent et enrichissent votre salle de bains Azzurra

Ästhetische Details, funktionale, technische und ergonomische Lösungen, die Ihrem Badezimmer Azzurra einen Mehrwert und Prestige verleihen

Detalles estéticos, soluciones funcionales, medidas técnicas y ergonómicas que agregan valor y prestigio a vuestro baño Azzurra



① Il pensile può avere un elemento terminale a giorno coperto solo parzialmente dall'anta / The wall unit can have an open end element only partially covered by the door / Le placard peut avoir un élément terminal ouvert, couvert seulement en partie par la porte / Der Hängeschrank kann ein Abschlusselement haben, das nur teilweise von der Tür verdeckt ist / El armario puede tener un elemento terminal abierto cubierto sólo parcialmente por la puerta



② Specchiera Therapy, con illuminazione di cortesia, lampada Led integrata e mensoline scorrevoli in acciaio / Therapy wall mirror with courtesy lighting, an integrated Led light and sliding steel shelves / Miroir Therapy, avec éclairage de service, lampe à Led intégrée et étagères coulissantes en acier / Wandspiegel Therapy mit Beleuchtung, integrierter LED-Lampe und verschiebbaren Ablagen aus Stahl / Espejo Therapy, con iluminación de posición, lámpara LED integrada y repisas correderas de acero

③ Un accorgimento progettuale offre l'effetto di base "sospesa" pur avendo il mobile appoggiato al pavimento / A design trick that offers a "suspended" effect, despite the element being rested on the floor / Un détail conceptuel offre l'effet de base "suspendue" tout en ayant le meuble qui repose sur le sol / Diese Projektlösung bietet die Wirkung eines hängenden Unterschranks, obwohl das Möbelstück auf dem Boden aufliegt / Una intuición de diseño ofrece el efecto de base "colgante" pese a tener el mueble apoyado en el suelo



④ Ai mobili con maniglia è possibile affiancare moduli con ante lisce con apertura push pull / Elements with handle can be matched with elements featuring smooth doors and a push-pull opening / Il est possible d'assembler aux meubles à poignée des modules à portes lisses avec ouverture push pull / Die Möbel mit Griffen können mit Modulen mit glatten Türen mit Push&Pull-Öffnungssystem kombiniert werden / A los muebles con tirador se pueden combinar módulos con puertas lisas con apertura push pull

⑥ Alcuni piani top in materiali di tendenza vengono proposti con vasche di design esclusivo per Azzurra / Some tops in trendy materials are offered with sinks designed exclusively for Azzurra / Certains plans en matériaux de tendance sont proposés avec vasques de design exclusif Azzurra / Einige Abdeckplatte aus trendigen Materialien werden mit Waschbecken von Azzurra exklusiven design angeboten / Proponemos algunas encimeras de materiales de tendencia con lavabos diseñados exclusivamente para Azzurra



⑤ Il piano, il frontale e la struttura del mobile possono essere dello stesso materiale in HPL, Ecomalta e Fenix / The top, front and structure of the unit can be in the same material in HPL, Ecomalta and Fenix / Le plan, la façade et la structure du meuble peuvent être du même matériau : HPL, Ecomalta et Fenix / Die Waschtischplatte, die Front und die Konstruktion des Möbelstücks können aus demselben Material aus HPL, Ecomalta und Fenix sein / La encimera, el frente y la estructura del mueble pueden ser del mismo material de HPL, Ecomalta y Fenix



LE MANIGLIE

The handles
Les poignées
Die Griffe
Los Tiradores



7



8

8 LIME Ø può prevedere un innovativo fianco a giorno in metallo sul quale appoggiare il top nella finitura preferita / LIME Ø can also include an innovative open side unit in metal, on which to rest a top in the user's preferred finish / LIME Ø peut prévoir une côté ouverte en métal sur laquelle poser le plan dans la finition désirée / LIME Ø kann einen innovativen offenen Unterschrank aus Metall vorsehen, auf dem die Waschtischplatte im gewünschten Finish ruht / LIME Ø puede contemplar una innovadora base abierta de metal en la cual apoyar la encimera con el acabado preferido

7 La possibilità di combinare pensili di varie profondità permette di creare un intrigante gioco di volumi / The possibility to combine wall units with varying depths allows the development of an intriguing play of volumes / La possibilité d'associer des placards de différentes profondeurs permet de créer un jeu de volumes intrigant / Die Möglichkeit Hängeschränke verschiedener Tiefen zu kombinieren ermöglicht es, ein faszinierendes Spiel aus Rauminhalten zu schaffen / La posibilidad de combinar armarios de distintas profundidades permite crear un juego de volúmenes intrigantes



9



10

9 Specchiera Riquadro retroilluminata, con mensola e comodi supporti per tanti piccoli oggetti / Riquadro wall mirror, with backlit shelf and convenient supports for lots of little objects / Miroir Riquadro, avec étagère éclairée sur le fond et des supports pratiques pour ranger les petits objets / Wandspiegel Riquadro von hinten beleuchtet mit Ablage und bequemen Halterungen für viele kleine Gegenstände / Espejo Riquadro retroiluminado, con estante y cómodos soportes para muchos objetos pequeños

10 Speciali soluzioni a pianta curva permettono di aggiungere movimento e sensualità al locale bagno / Special solutions featuring a curved layout add movement and sensuality to the bathroom / Une poignée pour donner au meuble une touche de caractère / Ein Designgriff, der dem Möbelstück Charakter verleiht / Un tirador de diseño que firma el mueble con carácter



DISKO 1

1 DISKO* Personalità e tecnologia in una forma perfetta / Personality and technology in a perfect shape / Personnalité et technologie en une forme époustouflante / Persönlichkeit und Technologie in einer perfekten Form / Personalidad y tecnología en una forma perfecta



ICON 2

2 ICON * Una maniglia di design che firma il mobile con carattere / A designer handle adding a statement to furniture / Une poignée pour donner au meuble une touche de caractère / Ein Designgriff, der dem Möbelstück Charakter verleiht / Un tirador de diseño que firma el mueble con carácter



PARENTESI 3

3 PARENTESI Una forma originale e un'esecuzione perfetta. Anche in combinazione di due / An original shape, perfectly executed / Une forme originale et une exécution parfaite / Eine originelle Form und eine perfekte Ausführung / Una forma original y una ejecución perfecta



SASSO 4

4 SASSO Un tocco di eleganza con la possibilità di accostare la maniglia Sasso alla specchiera coordinata / A touch of elegance with the possibility to match the Sasso handle with the coordinated wall mirror / Une touche élégante avec la possibilité d'assembler la poignée Sasso à le miroir coordonné / Ein Touch Eleganz mit der Möglichkeit dem passenden Griff Sasso mit den Wandspiegel zu kombinieren / Un toque de elegancia con la posibilidad de combinar el tirador Sasso con el espejo haciendo juego

* Maniglie con maggiorazione di prezzo per versione rivestita Ecomalta
* Handle with price surcharge for the Ecomalta coated version
* Supplément pour les poignées appartenant à la version revêtue Ecomalta
* Griffe mit Aufpreis für die beschichtete Ecomalta-Version
* Tiradores con incremento de precio para versión revestida con Ecomalta

⑤ FLY* Elegante e leggera, unisce stile e praticità / Elegant and lightweight, combining style and practicality / Élégante et légère, elle unit le style et la praticité / Elegant und leicht, verbindet Stil und Zweckmäßigkeit / Elegante y liviana, une estilo y practicidad



FLY ⑤



LIKE ⑥

⑥ LIKE La classe di un gioiello, a scelta singola o accoppiata / The sophistication of a gem, on its own or in pairs / La classe d'un bijou, à choisir simple ou double / Die Klasse eines Juwels, nach Wunsch einzeln oder paarweise / La clase de una joya, con elección individual o combinada

⑦ LATERAL* Una maniglia che gioca con gusto con le forme del mobile / A handle focusing on the shape of the unit / Une poignée qui joue élégamment avec les formes du meuble / Ein Griff, der geschmackvoll mit den Formen des Möbelstücks spielt / Un tirador que juega con gusto con las formas del mueble



LATERAL ⑦



SIMPLE ⑧

⑧ SIMPLE* La maniglia Simple laccata nella stessa finitura e tono del frontale, design e discrezione / The Simple handle lacquered in the same finish and colour as the door, design and discretion / Poignée Simple laquée dans la même finition et tonalité que la porte, design et discrétion / Der Griff Simple lackiert in demselben Finish und Farbton wie die Tür, das Design nach Wunsch / El tirador Simple lacado del mismo acabado y tono de la puerta, diseño y discreción



DELTA ⑨

⑨ DELTA Ergonomica e sottile, pratica anche come portasciugamani / Slim-line and ergonomic; doubles as a handy towel rail too / Ergonomique et étroite, elle devient un porte-serviettes extrêmement pratique / Ergonomisch und dünn, fungiert auch als Handtuchhalter / Ergonómico y sutil, práctico también como toallero

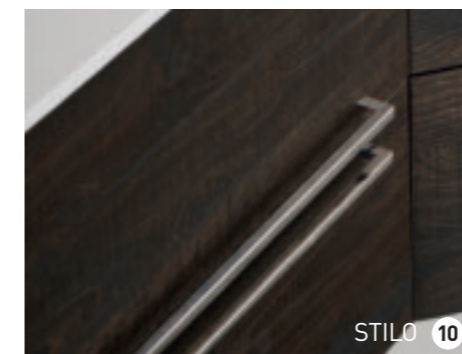

STILO ⑩

⑩ STILO A sezione quadrata, può essere singola o doppia e fungere da portasciugamani / With a square section, it can be used on its own or combined, for use as a towel rail / À section carrée, simple ou double, elle peut être utilisée comme porte-serviettes / Mit quadratischem Querschnitt, einzeln oder paarweise einsetzbar und fungiert auch als Handtuchhalter / De sección cuadrada, puede ser individual o doble y servir como toallero

⑪ ML A sezione quadrata, è disponibile anche curva, perfetta come portasciugamani / With a square section, a curved version is also available; the perfect place to hang your towel / À section carrée, elle est disponible aussi cintrée et peut être utilisée comme porte-serviettes / Mit quadratischem Querschnitt, auch geschwungen erhältlich, perfekt als Handtuchhalter / De sección cuadrada, está disponible también curvo, perfecto como toallero



ML ⑪



BRIO ⑫

⑫ BRIO A sezione ovale, segna il frontale con una linea pulita; è anche pratico portasciugamani / With an oval section, it stamps a clean line on the front panel; can be used as a towel rail too / À section ovale, elle dessine clairement la façade et peut être utilisée comme porte-serviettes / Mit ovalem Querschnitt, verleiht der Front eine klare Linie; auch praktisch als Handtuchhalter / De sección oval, marca el frente de una línea sobria; es también un práctico toallero

* Maniglie con maggiorazione di prezzo per versione Laccata o rivestita Ecomalta
 * Handle with price surcharge for the Ecomalta coated and lacquered version
 * Supplément pour les poignées appartenant à la version laquée ou revêtue Ecomalta
 * Griffe mit Aufpreis für die lackierte oder beschichtete Ecomalta-Version
 * Tiradores con incremento de precio para versión Lacada o revestida Ecomalta

LE MANIGLIE PER I FRONTALI CURVI

Handles for curved front panels

Les poignées pour les façades cintrées

Die Griffe für die Geschwungenen Fronten

Los tiradores para los frentes curvos



BRIO curva 13

13 BRIO curva Con sezione ovale, è utilizzabile come portasciugamani / With an oval section, it can be used as a towel rail / À section ovale, elle peut être utilisée comme porte-serviettes / Mit ovalem Querschnitt, kann auch als Handtuchhalter verwendet werden / Con sección oval, se puede utilizar como toallero



SIMPLE 14

14 SIMPLE* La maniglia Simple laccata nella stessa finitura e tono del frontale, design e discrezione / The Simple handle lacquered in the same finish and colour as the door, design and discretion / Poignée Simple laquée dans la même finition et tonalité que la porte, design et discrétion / Der Griff Simple lackiert in demselben Finish und Farbton wie die Tür, das Design nach Wunsch / El tirador Simple lacado del mismo acabado y tono de la puerta, diseño y discreción

* Maniglie con maggiorazione di prezzo per versione Laccata o rivestita Ecomalta
 * Handle with price surcharge for the Ecomalta coated and lacquered version
 * Supplément pour les poignées appartenant à la version laquée ou revêtue Ecomalta
 * Griffe mit Aufpreis für die lackierte oder beschichtete Ecomalta-Version
 * Tiradores con incremento de precio para versión Lacada o revestida Ecomalta



LIKE 15

15 LIKE Disponibile in due misure, da scegliere singola, in coppia o in coppia alternata / Available in two sizes; choose one on its own, in pairs or in alternating pairs / Deux tailles différentes, à choisir simple ou double ou version double alternée / In zwei Größen erhältlich, die einzeln, paarweise oder paarweise im Wechsel gewählt werden können / Disponible en dos medidas, para elegir individual, doble o doble alternado

17 ML curva** Robusta e pratica, ha sezione quadrata e può fungere da portasciugamani / Sturdy and practical with a square section, it can be used as a towel rail / Résistante et pratique, section carrée, elle peut être utilisée comme porte-serviettes / Robust und praktisch, mit quadratischem Querschnitt, dient auch als Handtuchhalter / Resistente y práctico, tiene sección cuadrada y puede servir como toallero



STILO curva 16

16 STILO curva** Da scegliere singola o doppia, ha sezione quadrata ed è anche un comodo portasciugamani / Opt for one or two, it has a square section and makes a handy towel rail / À choisir entre simple ou double, section carrée, elle peut être utilisée comme porte-serviettes / Einzeln oder paarweise erhältlich, mit quadratischem Querschnitt und praktisch auch als Handtuchhalter / Para elegir individual o doble, tiene sección cuadrada y es también un cómodo toallero



ML curva 17

** Maniglie con maggiorazione di prezzo
 ** Handles with price surcharge
 ** Supplément pour les poignées
 ** Griffe mit Aufpreis
 ** Tiradores con incremento de precio

TECHNICALS

DEKORATIVO 3D

Melaminico usato per realizzare strutture, frontali, elementi giorno, top, fianchi di tamponamento e anche per il rivestimento delle gole.

Melaminico used to develop structures, doors, open elements, tops, buffer side panels and even for the coating of grooves.

Melaminico Utilisé pour réaliser les structures, les portes, les éléments ouvert, les plans de toilettes, les joues mais aussi pour le revêtement des gorges.

Melaminico verwendet für Konstruktionen, Türen, offene Elemente, Waschtischplatten, Abdichtflächen und auch für die Verkleidung von Griffmulde.

Melaminico usado para realizar estructuras, puertas, elementos abiertos, encimeras, perfiles de tapadura para el revestimiento de las golas.

ROVERE SHERWOOD



CHIARO - 1S1



CASTANO - 1S3



SCURO - 1S2

ROVERE DOGATO

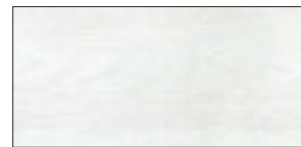

BIANCO - 1P0



GRIGIO - 1P1

EUCALIPTO SABLÈ



GRIGIO - 1SA



CANALETTO - 1SB

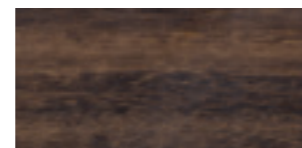

TERMOCOTTO - 1SC

NODATO SPACCATO



BIONDO - 1NA



TABACCO - 1NB

CEMENTO

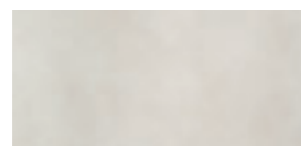

CENERE - 1A1

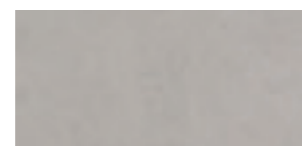

TORTORA - 1A2



CRETA - 1A3

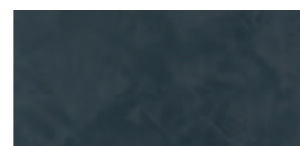

OLTREMARE - 1A4

Disponibile solo per basi e pensili a giorno top e fianchi di tamponamento.

Available only for bases and open wall units, tops and buffer side panels.

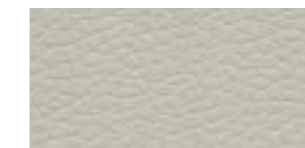

PRIMOFIORE EFFETTO PELLE CANAPA
1PC

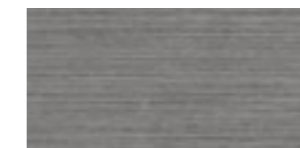

REFLEX EFFETTO METALLIZZATO
1RE

Disponibile uniquement pour les éléments bas et les meubles suspendus ouverts, le plan et les joues.

Erhältlich nur für offene Unterschränke und Hängeschränke, Waschtischplatten und Abdichtflächen.

Disponibile sólo para muebles y armarios abiertos, encimeras y perfiles de tapadura.

HPL UNICOLOR

Usato per realizzare strutture, frontali, elementi giorno, top e top con vasca integrata, fianchi di tamponamento e anche per il rivestimento delle gole.

Used to develop structures, doors, open elements, tops, buffer side panels and even for the coating of grooves. Tops can also be developed with a recessed basin.

Utilisé pour réaliser les structures, les portes, les éléments ouvert, les plans de toilettes, les joues mais aussi pour le revêtement des gorges.

Il est également possible de réaliser les plans de toilette avec vasque intégrée.

Verwendet für Konstruktionen, Türen, offene Elemente,

Waschtischplatten, Abdichtflächen und auch für die Verkleidung der Griffmulden. Die Waschtischplatten können auch mit eingelassenem Waschbecken umgesetzt werden.

Usado para realizar estructuras, puertas, elementos abiertos,

encimeras, perfiles de tapadura para el revestimiento de las golas. También se pueden realizar las encimeras con el lavabo integrado.



ROVERE WAFER - TK2



ROVERE MONET - TK3



ROVERE SLAVONIA - TK6

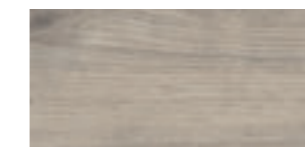

QUERCIA GRIGIA - TK4



NOCE SAVOIA - TKG



ARDESIA - TKF

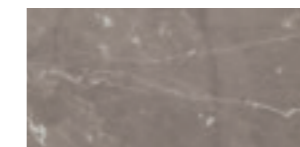

BOTTICINO - TK1

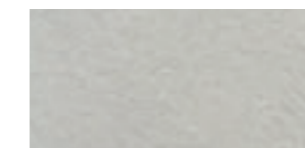

MALTA GRIGIA - TKE



MALTA CANAPA - TKD

FENIX®

È un materiale opaco che offre prestazioni tecnologiche all'avanguardia grazie alle sue caratteristiche superficiali. Usato per realizzare strutture, frontali, elementi giorno, top e top vasca integrata, fianchi di tamponamento e anche per il rivestimento delle gole.

This is a matt material that offers technologically advanced performance thanks to its surface characteristics. Used to develop structures, doors,

open elements, tops, buffer side panels and even for the coating of grooves. Tops can also be developed with a recessed basin.

Il s'agit d'un matériau mat qui offre des performances technologiques à l'avant-garde grâce à ses caractéristiques superficielles. Utilisé pour réaliser les structures, les portes, les éléments ouverts, les plans de toilette, les joues mais aussi le revêtement des gorges. Il est

également possible de réaliser les plans de toilette avec vasque intégrée.

Ist ein mattes Material, das dank seiner Oberflächeneigenschaften hochtechnologische Leistungen bietet. Verwendet für Konstruktionen, Türen, offene Elemente, Arbeitsplatten und Abdichtflächen und auch für die Verkleidung der Einschnitte. Die Waschtischplatten können auch mit eingelassenem

Waschbecken umgesetzt werden.

Es un material opaco que ofrece prestaciones tecnológicas de vanguardia gracias a sus características superficiales. Usado para realizar estructuras, puertas, elementos abiertos, encimeras, perfiles de tapadura y también para el revestimiento de las golas. También se pueden realizar las encimeras con lavabo integrado.

SOFT TOUCH COLOURS

Laccato opaco con finitura superficiale morbida al tatto. **Abbinabili agli stessi colori dei top con vasca integrata realizzati in Fenix.** Usato per realizzare strutture, frontali, elementi giorno, top, fianchi di tamponamento e anche per il rivestimento delle gole.

Matt laquered colors with soft touch surface. **Compatible with the same colors of the tops with integrated basin made**

in Fenix. Used to develop structures, doors, open elements, tops, buffer side panels and even for the coating grooves.

Couleurs laquées mates avec surface douce au toucher. **Compatibles avec les mêmes couleurs des plans avec vasque intégrés fabriqués en Fenix.** Utilisé pour réaliser les structures, les portes, les éléments ouverts, les plans, les joues et aussi les revêtements des gorges.

Lakierte matte Farben mit weichen Oberfläche. **Kombinierbaren mit den selben Farben von den Abdeckplatten mit integrierten Waschbecken aus Fenix.** Verwendet für Konstruktionen, Türen, offene Element, Waschtischplatten, Abdichtflächen und auch für die Verkleidung der Einschnitte.

Lacas mates con tacto suave. **Combinables con los mismos acabados de**

las encimeras con lavabo integrado realizadas en Fenix. Usado para realizar estructuras, puertas, elementos abiertos, encimeras, perfiles de tapadura para el revestimiento de las golas.

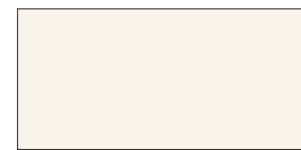

BIANCO MALÈ - TFA



GRIGIO EFESO - TFB



CASTORO OTTAWA - TFC



CACAO ORINOCO - TFF



GRIGIO LONDRA - TFD



GRIGIO BROMO - TFE



ROSSO JAIPUR - TFH



VERDE COMODORO - TFG

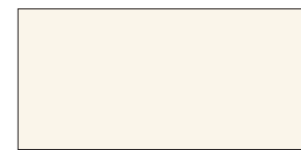

BIANCO MALÈ - 8FA



GRIGIO EFESO - 8FB



CASTORO OTTAWA - 8FC



CACAO ORINOCO - 8FF



GRIGIO LONDRA - 8FD



GRIGIO BROMO - 8FE



ROSSO JAIPUR - 8FH



VERDE COMODORO - 8FG



Bassa riflessione della luce, superficie estremamente opaca / Low light reflectivity, extremely matt surface / Faible réflectivité, surface extrêmement mate / Geringe Lichtreflexion, extrem matte Oberfläche / Reflectancia mínima de la luz, superficie extremadamente mate



Riparabilità termica dei micrograffi / Thermal healing of microscratches / Réparation thermique des micro-rayures / Thermische Bearbeitung von Kratzen möglich / Reparabilidad térmica di microarañazos



Elevata resistenza a solventi acidi e ai reagenti di uso domestico / High resistance to acid solvents household reagents / Grande résistance aux solvants et nettoyeurs ménagers / Resistente gegen säurehaltige und alle haushaltsüblichen Reiniger / Alta resistencia a disolvente ácidos y reactivos para uso doméstico



Alta attività di abbattimento della carica batterica / Enhanced anti-bacterial properties / Propriétés antibactériennes renforcées / Verbesserte antibakterielle Eigenschaften / Propiedad anti-bacterias reforzada



Resistenza ai graffi all'abrasione / Resistance to scratches and abrasion / Résistance aux rayures et à l'abrasion / Resistent gegen Kratzer und Abrieb / Resistencia a los arañazos y a la abrasión



Resistenza al calore secco / Resistance to dry heat / Résistance à la chaleur sèche / Resistent gegen trockene Hitze / Resistencia al calor seco



Anti-impronta / Anti-fingerprint / Aucune trace de doigts / Keine Fingerabdrucke / Anti-huella digital



Morbidezza al tatto / Soft touch / Toucher soyeux / Weicher Touch / Suave al tacto

ECOMALTA®

È un materiale naturale applicato artigianalmente con diversi passaggi. Usato per realizzare strutture, frontali, top, fianchi di tamponamento e anche per il rivestimento delle gole. Si possono anche realizzare i top con vasca integrata.

This is a natural material applied using techniques, in a series of steps. Used to develop structures, doors, tops, buffer side panels and even for the coating of grooves. Tops can also be developed with a recessed basin.

Il s'agit d'un matériau naturel appliqué artisanalement en plusieurs couches. Utilisé pour réaliser les structures, les portes, les plans de travail, les joues mais aussi le revêtement des gorges. Il est également possible de réaliser les plans de toilette avec vasque intégrée.

Es ist ein natürliches Material, das handwerklich mit verschiedenen Schritten aufgebracht wird. Verwendet für Konstruktionen, Türen, Waschtischplatten,

Abdicht-flächen und auch für die Verkleidung der Einschnitte. Die Waschtischplatten können auch mit eingelassenem Waschbecken umgesetzt werden.

Es un material natural aplicado artesanalmente con diferentes pasos. Usado para realizar estructuras, puertas, encimeras, perfiles de tapadura y también para el revestimiento de las golas. También se pueden realizar las encimeras con lavabo integrado.

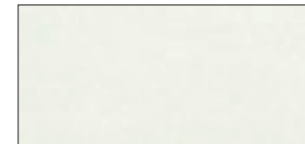

BIANCO - TCA

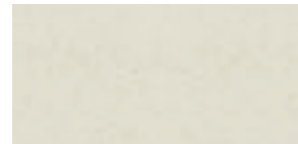

GHIACCIO - TCF

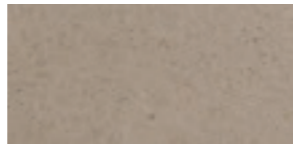

CORDA - TCB

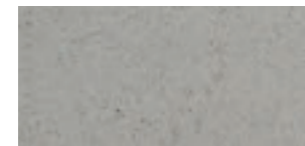

GRIGIO CHIARO - TCC



ARDESIA - TCD

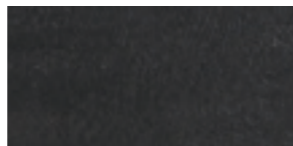

ANTRACITE - TCE

ECOMALTA® “LE TERRE”

È un materiale naturale applicato artigianalmente con diversi passaggi, **con l'aggiunta di pigmenti naturali colorati**. Usato per realizzare strutture, frontali, top, fianchi di tamponamento e anche per il rivestimento delle gole. Si possono anche realizzare i top con vasca integrata.

This is a natural material applied using traditional techniques, in a series of steps, **with the addition of colored natural pigments**. Used to develop structures, doors, tops, bufferside panels and even for the coating of grooves. Tops can also be developed with a recessed basin. Il s'agit d'un matériau naturel appliqué

artisanalmente en plusieurs couches, **avec l'ajout de pigments naturels colorés**.

Utilisé pour réaliser les structures, les portes, les plans de travail, les joues mais aussi le revêtement des gorges. Il est également possible de réaliser les plans de toilette avec vasque intégrée.

Es ist ein natürliches Material, das handwerklich mit verschiedenen Schritten aufgebracht wird, **mit der Zugabe von gefärbten natürlichen Pigmenten**. Verwendet für Konstruktionen, Türen, Waschtischplatten, Abdicht-flächen und auch für die Verkleidung der Einschnitte. Die Waschtischplatten

können auch mit eingelassenem Waschbecken umgesetzt werden.

Es un material natural aplicado artesanalmente con diferentes pasos, **con la adición de pigmentos naturales coloreados**. Usado para realizar estructuras, puertas, encimeras, perfiles de tapadura y también para el revestimiento de las golas. También se pueden realizar las encimeras con lavabo integrado.

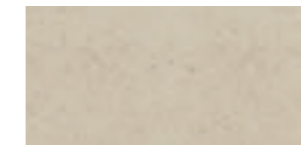

LIMO - TCP



SIENA - TCQ

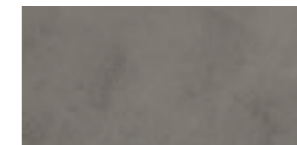

ARGILLA - TCR

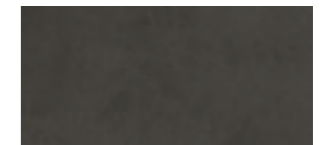

TORBA - TCS

COLOURS



LACCATI OPACHI (O.) E LUCIDI (L.) /
MATT (O.) AND GLOSS (L.) COLOURS /
COULEURS LAQUES MATES (O.) ET

BRILLANTES (L.) / LACKIERUNGEN
IN MATT (O.) UND HOCHGLANZ (L.) /
LACADOS MATES (O.) Y BRILLANTES (L.)

						
BIANCO L. 30B - O. 20B	BIANCO CONCHIGLIA L. 375 - O. 275	CAPPUCCINO L. 388 - O. 288	CANYON L. 390 - O. 290	NEBBIA L. 391 - O. 291	CENERE L. 392 - O. 292	TITANIO L. 393 - O. 293
						
ROSA CIPRIA L. 313 - O. 213	ROSA SCURO L. 3A0 - O. 2A0	GIALLO CURRY L. 308 - O. 208	GIALLO ZAFFERANO L. 3A1 - O. 2A1	ARANCIO ZUCCA L. 309 - O. 209	ARANCIO L. 322 - O. 222	ARAGOSTA L. 377 - O. 277
						
ROSSO FUOCO L. 321 - O. 221	ROSSO RUBINO L. 319 - O. 219	ROSSO MELANZANA L. 320 - O. 220	GLICINE L. 371 - O. 271	LAVANDA L. 332 - O. 232	MIRTILLO L. 372 - O. 272	BIANCO GHIACCIO L. 330 - O. 230
						
VERDE GHIAIA L. 3A8 - O. 2A8	VERDE POLVERE L. 334 - O. 234	VERDE MELA L. 324 - O. 224	VERDE MUSCHIO L. 3A4 - O. 2A4	AZZURRO FREDDO L. 3A5 - O. 2A5	AZZURRO CIELO L. 335 - O. 235	BLU PAVONE L. 3A6 - O. 2A6
						
BLU LAGUNA L. 3A7 - O. 2A7	BLU PASTELLO L. 340 - O. 240	BLU ARTICO L. 337 - O. 237	BLU ELETTRICO L. 338 - O. 238	CACAO L. 305 - O. 205	CAFFÈ L. 304 - O. 204	MARRONE HAVANA L. 379 - O. 279
						
GRIGIO CHIARO L. 3A8 - O. 2A8	GRIGIO LUCE L. 307 - O. 207	GRIGIO PERLA L. 333 - O. 233	GRIGIO LAVAGNA L. 3A9 - O. 2A9	GRIGIO GRAFITE L. 302 - O. 202	NERO L. 303 - O. 203	

COLORI METALLIZZATI /
METALLIC COLOURS /
COLORIS MÉTALLISÉS /

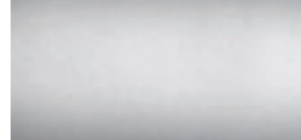
FARBEN METALLISIERT /
COLORES METALIZADOS

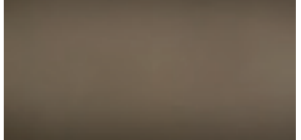
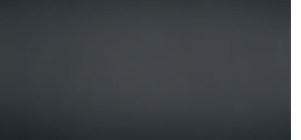
			
ALLUMINIO METALLIZZATO L. 3M1 - O. 2M1	CRETA METALLIZZATO L. 3M6 - O. 2M6	BRONZO METALLIZZATO L. 3M4 - O. 2M4	ANTRACITE METALLIZZATO L. 3M5 - O. 2M5

VERSIONI DISPONIBILI
NEI 45 COLORI /
VERSIONS AVAILABLE
IN 45 COLORS /

VERSIONS DISPONIBLES
EN 45 COLORIS /
VERSIONEN ERHÄLTICH
IN 45 FARBEN /

VERSIONES DISPONIBLE
EN LOS 45 COLORES

		
COLORE OPACO LISCIO	COLORE LUCIDO LISCIO	NUANCE OPACO ROVERE DOGATO LACCATO

METAL COLOURS

Laccati metal Laccato opaco con componenti metallici (senza metalli pesanti), applicato artigianalmente con diversi passaggi.

metallic components (without heavy metals), applied using traditional techniques in a series of steps.

lourds), appliqués artisanalement en plusieurs couches.

mit verschiedenen Schritten.

Lacquered metals
Matt lacquered with

Laqués metal Laqué mat avec des composants métalliques (sans métaux

Lackiert metal Lackiert matt mit Metallkomponenten (ohne schwere Metalle), handwerklich angebracht

Lacados metal Lacado opaco con componentes metálicos (sin metales pesados), aplicado artesanalmente con diferentes pasos.

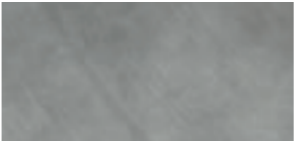
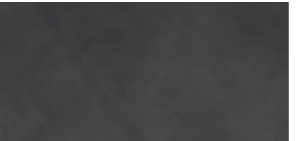
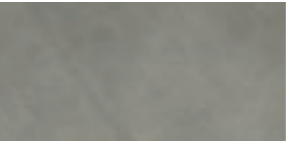
			
ACCIAIO - 2MA	PIOMBO - 2MB	TITANIO - 2MC	BRONZO - 2MD

Coordinamento marketing

Pais e Associati

Upgrade Lime Ø e Direzione artistica

Sciuto Architetti.it

Design lavabi Oly/Tivi

Studio Arter & Citton

Fotografia

Gabriotti fotografi

Styling

Carla Bernardis

Grafica e testi

adsGlen

Fotolito

Lucegroup

Stampa

Grafiche Antiga

Si ringrazia

NEWFORM spa

AZZURRA GROUP SRL

33087 Cecchini di Pasiano (PN) Italia

Via Codopè, 62

tel +39 0434 611 056

fax +39 0434 611 066

info@azzurrabagni.com

www.azzurrabagni.com

Stampato febbraio 2018

È vietata la riproduzione, anche parziale, di questo catalogo in qualsiasi forma e su qualsiasi supporto senza l'autorizzazione di Azzurra Group s.r.l.

Total or partial reproduction by any means of this catalogue is forbidden without authorization from Azzurra Group s.r.l.

